

# B25A20AC SERIES BRUSHLESS SERVO AMPLIFIERS

## Model: B25A20AC

### 120VAC Single Supply Operation

**FEATURES:**

- Surface-mount technology
- Small size, low cost, ease of use
- Built-in input signal isolation and shunt regulator
- DIP switch selectable modes:  
current, open loop, tachometer, HALL velocity
- Four quadrant regenerative operation
- Agency approvals:

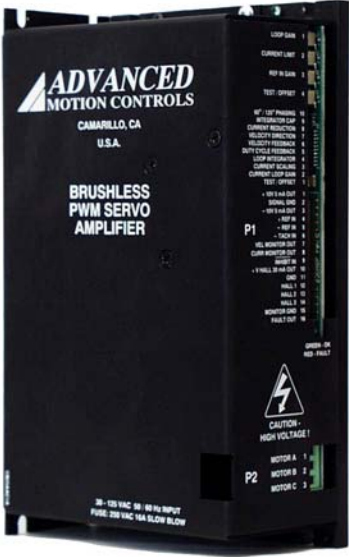

**BLOCK DIAGRAM:**

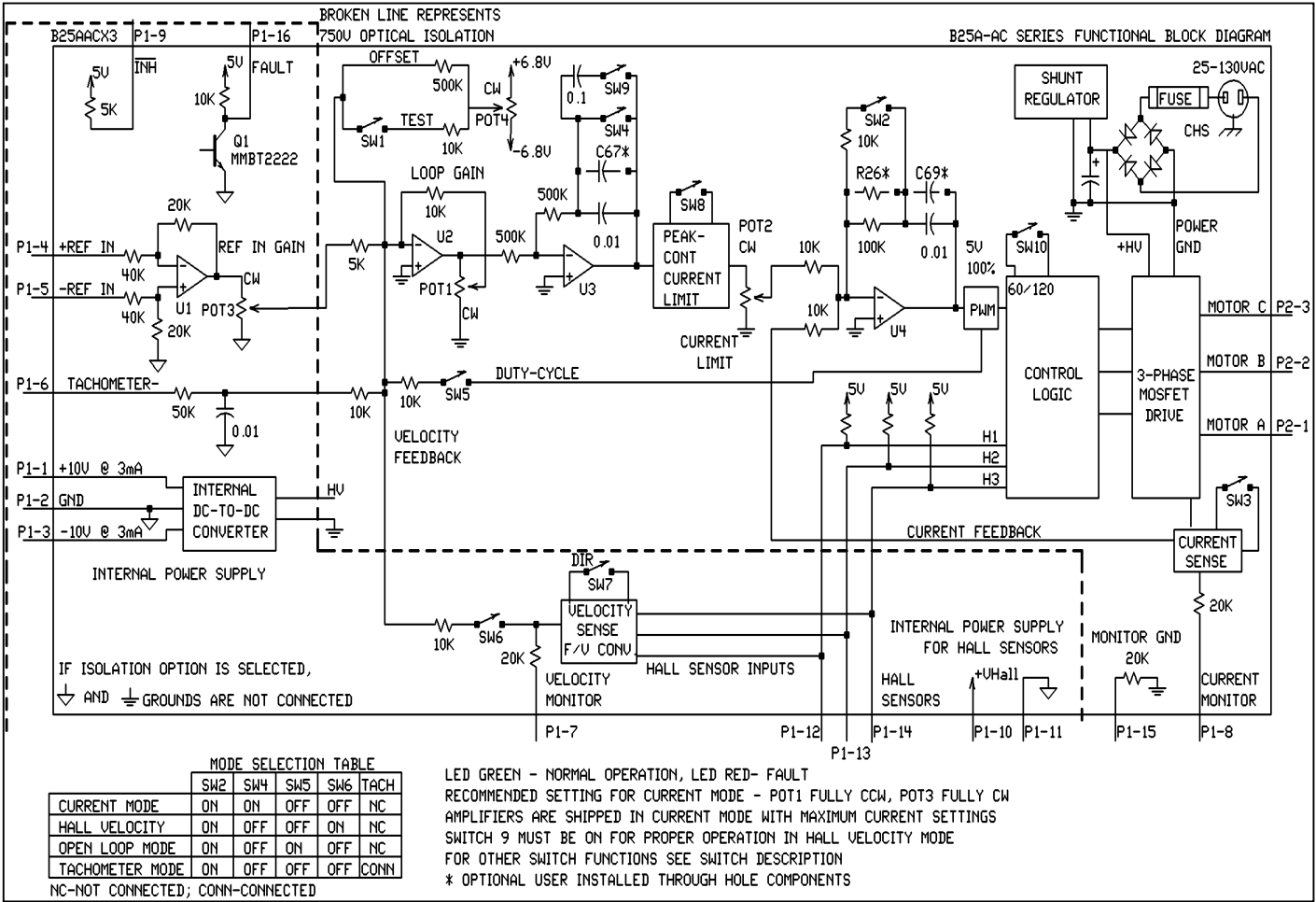

**DESCRIPTION:** The B25A20AC Series PWM servo amplifiers are designed to drive brushless DC motors at a high switching frequency. The B25A20AC is fully protected against over-voltage, over-current, over-heating and short-circuits. This model interfaces with digital controllers or can be used as a stand-alone drive and requires only a single unregulated AC power supply. A single red/green LED and a single digital output indicate operating status. Loop gain, current limit, input gain and offset can be adjusted using 14-turn potentiometers. The offset adjusting potentiometer can also be used as an on-board input signal for testing purposes, when SW1 (DIP switch) is ON.

**SPECIFICATIONS:**

All B25A20AC specifications are identical to the B25A20 specifications (see B30A series data sheets) except for:

	MODEL
<b>POWER STAGE SPECIFICATIONS</b>	<b>B25A20AC</b>
SINGLE PHASE AC SUPPLY VOLTAGE	30 - 125 VAC @ 50-60 Hz
SHUNT RESISTOR	10 $\Omega$ @ 50 W
SHUNT SWITCH-ON VOLTAGE*	185 VDC
BUS CAPACITANCE	3600 $\mu$ F
SHUNT FUSE (d=.25 inches, L=1.25 inches)	3 A Motor Delay rated @ 250 VAC
BUS FUSE (5x20 mm)	16 A slow-blow rated @ 250 VAC

MECHANICAL SPECIFICATIONS	
POWER CONNECTOR	Screw terminals
SIGNAL CONNECTOR	Molex connector
SIZE	7.36 x 4.23 x 2.45 inches 186.7 x 107.4 x 62.2 mm
WEIGHT	2.6 lb. 1.14 kg

\* If the shunt regulator is disabled the shut down voltage is 195 VDC.

These amplifiers contain a rectifier bridge and filter capacitors to generate the DC bus internally from the AC input power. The DC bus voltage is 1.4 times AC voltage (RMS), e.g. 170 VDC from 120 VAC. During braking much of the stored mechanical energy is fed back into the power supply and charges the output capacitor to a higher voltage. If the charge reaches the amplifier's over-voltage shutdown point, output current and braking will cease. To ensure smooth braking of large inertial loads, a built-in "shunt regulator" is provided in this model. The shunt regulator will switch-on the internal power resistor when the bus voltage exceeds 185 VDC. This resistor then dissipates the extra energy of the DC bus.

**B25A20AC and B25A20 AMPLIFIER PIN OUT DIFFERENCES:**

A current reference output is not available on this drive since this pin is required for the MONITOR GND (P1-15).

**INPUT SIGNAL ISOLATION:**

All input and output signals are isolated from the power stage except CURR MONITOR OUT (P1-8), which is referenced to MONITOR GND (P1-15).

**ORDERING INFORMATION:**

Model: B25A20ACX

X indicates the current revision letter.

**TYPICAL SYSTEM WIRING:** See section "G".

**MOUNTING DIMENSIONS:** See page F-11.

## B30A SERIES BRUSHLESS SERVO AMPLIFIERS

### Models: B30A8, B25A20, B40A8, B40A20

**FEATURES:**

- Surface-mount technology
- Small size, low cost, ease of use
- Optional input signal isolation
- DIP switch selectable modes: current, open loop, tachometer, or HALL velocity
- Four quadrant regenerative operation
- Agency Approvals:



**BLOCK DIAGRAM:**

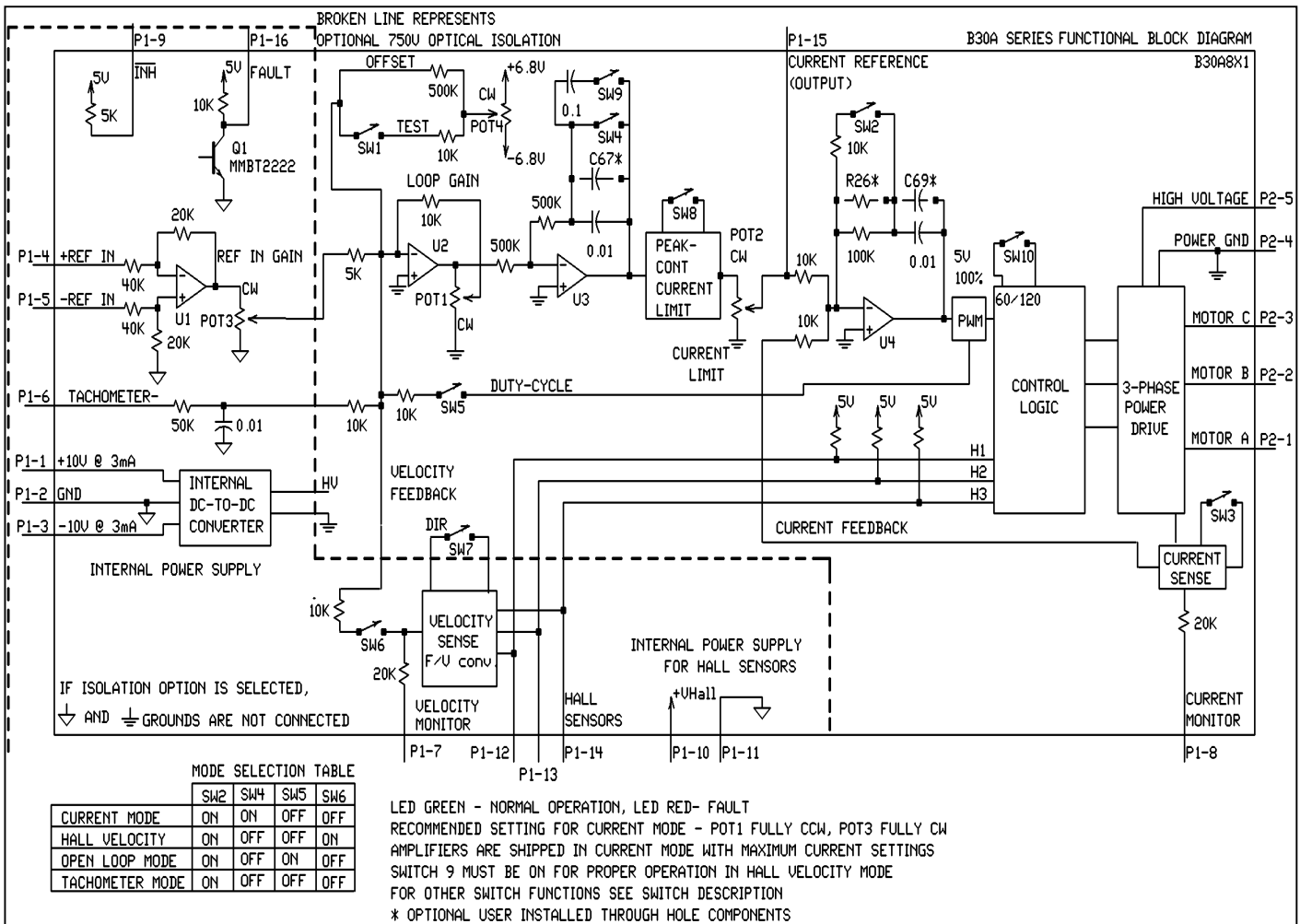
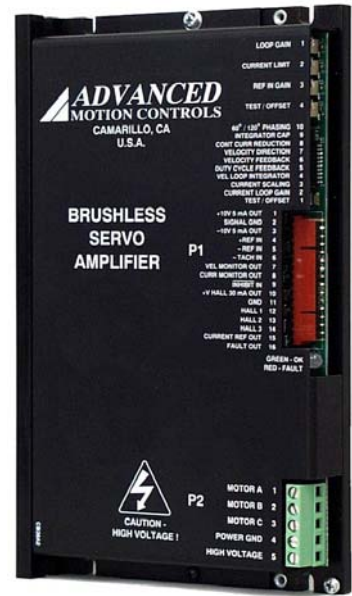

**ADVANCED MOTION CONTROLS**

3805 Calle Tecate, Camarillo, CA 93012 Tel: (805) 389-1935, Fax: (805) 389-1165

**DESCRIPTION:** The B30A Series PWM servo amplifiers are designed to drive brushless DC motors at a high switching frequency. They are fully protected against over-voltage, over-current, over-heating and short-circuits. All models interface with digital controllers or can be used as stand-alone drives. They require only a single unregulated DC power supply. A single red/green LED indicates operating status. Loop gain, current limit, input gain and offset can be adjusted using 14-turn potentiometers. The offset adjusting potentiometer can also be used as an on-board input signal for testing purposes when SW1 (DIP switch) is ON.

**SPECIFICATIONS:**

POWER STAGE SPECIFICATIONS	MODELS			
	B30A8	B25A20	B40A8	B40A20
DC SUPPLY VOLTAGE	20-80 V	40-190V	20-80V	40-190 V
PEAK CURRENT (2 sec. max., internally limited)	± 30 A	± 25 A	± 40 A	± 40 A
MAX. CONT. CURRENT (internally limited)	± 15 A	± 12.5 A	± 20 A	± 20 A
MINIMUM LOAD INDUCTANCE*	200 µH	250 µH	200 µH	250 µH
SWITCHING FREQUENCY	22 kHz ±15%			
HEATSINK (BASE) TEMPERATURE RANGE	0° to +65° C, disables if >65° C			
POWER DISSIPATION AT CONTINUOUS CURRENT	60 W	125 W	80 W	200 W
OVER-VOLTAGE SHUT-DOWN (self reset)	86 V	195 V	86 V	195 V
BANDWIDTH (load dependent)	2.5 kHz			

MECHANICAL SPECIFICATIONS	
POWER CONNECTOR	Screw terminals
SIGNAL CONNECTOR	Molex connector
SIZE	7.35 x 4.40 x 1.00 inches 186.7 x 111.7 x 25.4 mm
WEIGHT	1.5 lb. 0.68 kg

\* Low inductance motors require external inductors.

## PIN FUNCTIONS:

CONNECTOR	PIN	NAME	DESCRIPTION / NOTES	I/O
P1	1	+10V @ 3 mA OUT	For customer use	O
	2	SIGNAL GND	Reference ground	SGND
	3	-10V @ 3 mA OUT	For customer use	O
	4	+REF IN	Differential reference input, Maximum $\pm 15$ V, 40K input resistance	I
	5	-REF IN		
	6	-TACH IN	Tachometer input, max. $\pm 60$ VDC, 60K input resistance	I
	7	VELOCITY MONITOR OUT	Velocity monitor, 1 V = 133 Hz HALL sensor frequency	O
	8	CURRENT MONITOR OUT	Current monitor. Models B30A8 and B25A20: when SW3 is OFF, 1 V = 2 A, when SW3 is ON, 1 V = 4 A. Models B40A8 and B40A20: when SW3 is OFF, 1 V = 4 A, when SW3 is ON, 1 V = 8 A	O
	9	INHIBIT IN	This TTL level input signal turns off all power devices of the "H" bridge when pulled to ground. This inhibit will cause a fault condition and a red LED. For inverted inhibit input, see section "G".	I
	10	+V HALL 30 mA OUT	Power for HALL sensors, short circuit protected, +6 V @ +30 mA	O
	11	GND		SGND
	12	HALL 1	HALL sensor inputs, logic levels, internal 5 K $\Omega$ pull-up. Maximum low level input is 1.5 V, minimum high level input is 3.5 V.	I
	13	HALL 2		
	14	HALL 3		
	15	CURRENT REFERENCE OUT	Monitors the input signal connected directly to the internal current amplifier. 7.25 V = max peak current. See current limit adjustment information below.	O
	16	FAULT (red LED)	TTL level output. Becomes high during output short circuit, over-voltage, over temperature, inhibit, and during power-up reset. Fault condition indicated by red LED.	O
P2	1	MOTOR A	Motor phase A connection	O
	2	MOTOR B	Motor phase B connection	O
	3	MOTOR C	Motor phase C connection	O
	4	POWER GND	Power ground	PGND
	5	HIGH VOLTAGE	DC power input	I

**SWITCH FUNCTIONS:**

SWITCH	FUNCTION DESCRIPTION	SETTING	
		ON	OFF
1	Test / Offset. Sensitivity of the "offset" pot. Used as an on-board reference signal in test mode.	Test	Offset
2	Current loop gain	Decrease	Increase
3	Current scaling. When OFF, increases sensitivity of current sense thus reducing both peak and continuous current limit by 50%.	100%	50%
4	Velocity loop integrator. This capacitor normally ensures "error-free" operation in velocity mode by reducing the error-signal (output of summing amplifier) to zero.	Shorts out the velocity/voltage loop integrator capacitor	Velocity/voltage loop integrator Operating
5	Internal duty-cycle feedback for open loop mode.	On	Off
6	Velocity feedback. Connects the internally generated velocity signal from HALL sensors.	On	Off
7	Velocity direction. Changes the polarity of the velocity monitor signal.		
8	Continuous current reduction. Reduces continuous current limit by 50%.	Continuous / peak current limit ratio is 50%	Continuous / peak current limit ratio is 25%
9	Integrator capacitor. Adjusts the value of the integrator capacitor in velocity mode.	Increase	Decrease
10	60/120 degree commutation phase setting	120 degree phasing	60 degree phasing

**POTENTIOMETER FUNCTIONS:**

POTENTIOMETER	DESCRIPTION	TURNING CW
Pot 1	Loop gain adjustment in open loop & velocity modes. Turn this pot fully ccw in current mode.	Increases loop gain
Pot 2	Current limit. It adjusts both continuous and peak current limit maintaining selected ratio (50%).	Increases current limit
Pot 3	Reference in gain. It adjusts the ratio between input signal and output variables (voltage, current, velocity).	Increases reference input gain
Pot 4	Test / Offset. Used to adjust any imbalance in the input signal or in the amplifier. When SW1 (DIP switch) is ON, the sensitivity of this pot is greatly increased thus it can be used as an on-board signal source for testing purposes. See section "G".	N/A

**TEST POINTS FOR POTENTIOMETERS:** See section "G".

#### OPERATING MODE SELECTION:

These modes can be selected by the DIP switches according to the chart in the functional block diagram:

- Current mode
- Open loop mode
- Tachometer mode
- HALL velocity mode

See section "G" for more information.

**SET-UP:** See section "G" for engineering and installation notes.

#### CURRENT LIMIT ADJUSTMENTS:

These amplifiers feature separate peak and continuous current limit adjustments. The current limit adjustment Pot 2 adjusts both peak and continuous current limit at the same time. It has 12 active turns plus 1 inactive turn at each end and is approximately linear. Thus, to adjust the current limit turn the potentiometer fully counter-clockwise, then turn clockwise to the appropriate value.

In many applications it is sufficient to use only the DIP switches for current limit adjustments. SW3 reduces both peak and continuous current limit by 50% when OFF. SW8 reduces only the continuous current limit by 50% when OFF:

SW8	CONTINUOUS / PEAK CURRENT LIMIT RATIO
ON	50%
OFF	25%

P1-15 is the input to the internal current amplifier stage. Since the output current is proportional to P1-15, the adjusted current limit can easily be observed at this pin without connecting the motor. Note that a command signal must be applied to the reference inputs to obtain a reading on P1-15. The maximum peak current value equals 7.25 V at this pin and the maximum continuous current value equals 3.63 V at this pin. If SW3=ON, peak rated amplifier current = 7.25 V. If SW3=OFF,  $\frac{1}{2}$  peak rated amplifier current = 7.25 V. Example: using the B30A8 with SW3=ON, 30A=7.25V and with SW3=OFF, 15A=7.25V.

The actual current can be monitored at pin P1-8.

#### OPTIONAL INPUT SIGNAL ISOLATION:

750V optical input signal isolation is available for this amplifier series. It is recommended to use this option in transformer-less systems where the high voltage power is generated directly by rectifying the 120V AC line, or whenever one leg of the AC input to the power supply rectifier is grounded. All input and output signals are isolated from the power stage except CURRENT MONITOR OUT (P1-8) and CURRENT REFERENCE OUT (P1-15). P1-8 and P1-15 are referenced to POWER GND (P2-4).

B30A Series

**ORDERING INFORMATION:**

Models: B30A8X, B25A20X, B40A8X, B40A20X

With isolation:

Models: B30A8IX, B25A20IX, B40A8IX, B40A20IX

X indicates the current revision letter.

**TYPICAL SYSTEM WIRING:** See section "G".

**MOUNTING DIMENSIONS:** See page F-9.

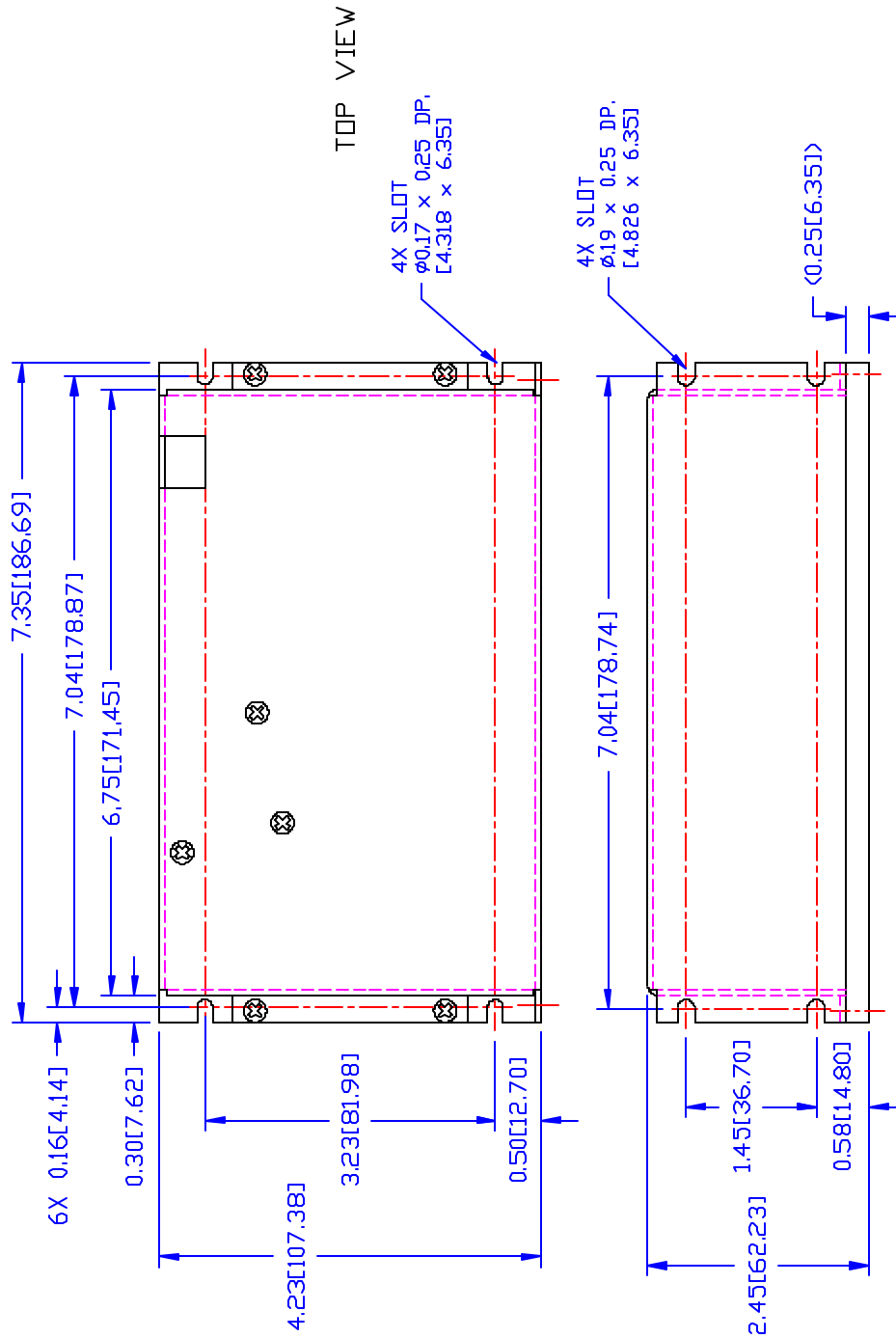

BACKSIDE VIEW

B	ADD BX25A20AC TO USED ON COLUMN	01/25/02	RB
A	UPDATE DWG. FORMAT & PICTORIAL	08/22/96	RB
REV	DESCRIPTION	DATE	BY

<p>ADVANCED MICROPOSITION CONTROLS • PWM SERVO AMPLIFIERS • 3805 Calle Tecate, Cananillo, CA 93012</p>	
TITLE MOUNTING DIMENSIONS B25A-AC & 30A-AC SERIES	
DRAWN BY: R. BAUTISTA	DATE: 10/06/95
CHECK BY:	DATE:
DESIGN APPROVED:	DATE:
USED ON BX25A20AC SERIES BE25A20AC SERIES B25A20AC SERIES BD25A-AC SERIES 30A-AC SERIES	SIZE DWG. NO. B MB25AAC
UNLESS OTHERWISE SPECIFIED, DIMENSIONS ARE IN INCHES TOLERANCES XX ± .010 XXX ± .005 DO NOT SCALE DRAWING	SCALE: NONE

NOTE: DIMENSIONS IN [ ] ARE IN MM.