

B30A40 SERIES BRUSHLESS SERVO AMPLIFIERS

Model: B30A40

FEATURES:

- Surface-mount technology
- Small size, low cost, ease of use
- Optical isolation, see block diagram
- Hall sensor commutation
- DIP switch selectable modes:
current, open loop, tachometer, external velocity, Hall velocity and encoder velocity
- Encoder and Hall velocity monitors
- Four quadrant regenerative operation
- Agency Approvals:



BLOCK DIAGRAM:

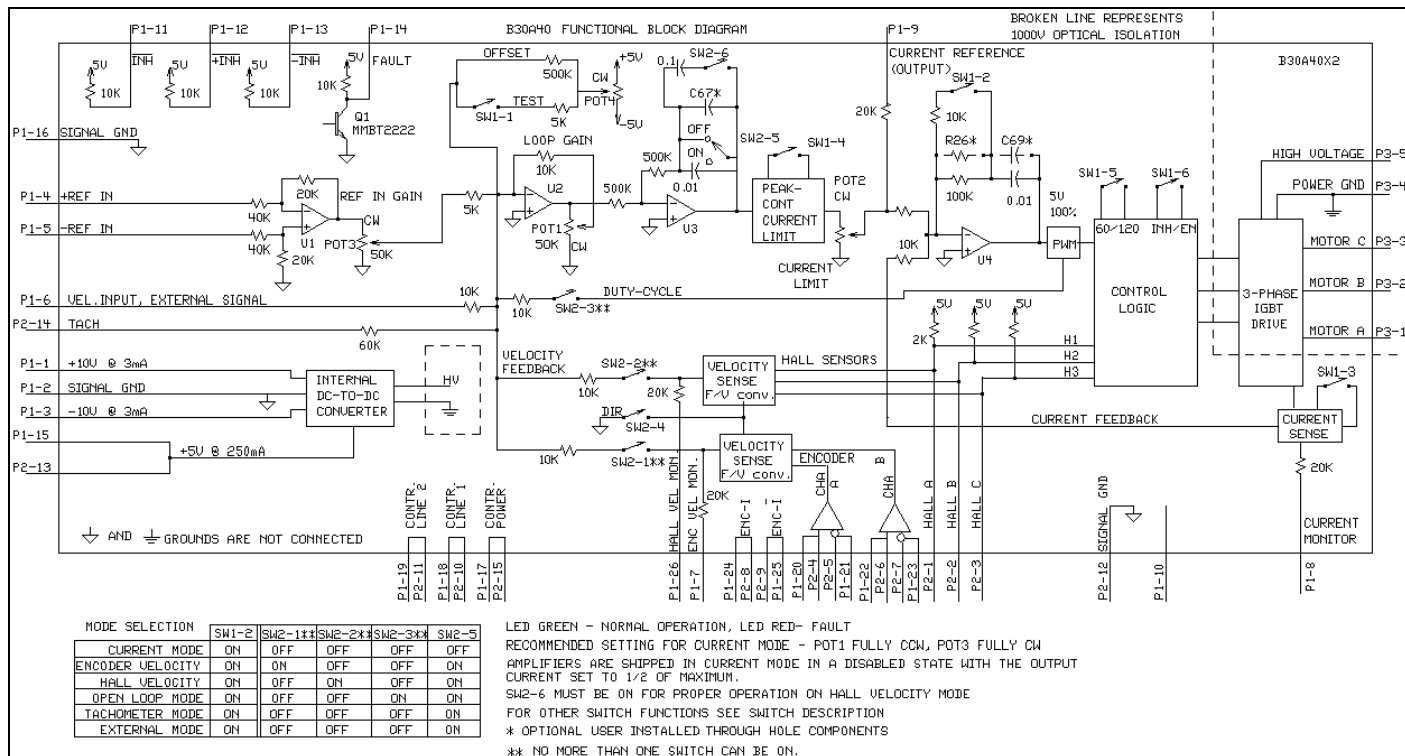

ADVANCED MOTION CONTROLS

3805 Calle Tecate, Camarillo, CA 93012 Tel: (805) 389-1935, Fax: (805) 389-1165

DESCRIPTION: The B30A40 Series PWM servo amplifiers are designed to drive brushless DC motors at a high switching frequency. They are fully protected against over-voltage, under-voltage, over-current, over-heating and short-circuits. All models interface with digital controllers or can be used as stand-alone drives. They require only a single unregulated DC power supply. A single red/green LED indicates operating status. Loop gain, current limit, input gain and offset can be adjusted using 14-turn potentiometers. The offset adjusting potentiometer can also be used as an on-board input signal for testing purposes when SW1-1 (DIP-switch) is ON.

SPECIFICATIONS:

	MODEL
POWER STAGE SPECIFICATIONS	B30A40
DC SUPPLY VOLTAGE	60 - 400 VDC
PEAK CURRENT (2 sec. max., internally limited)	± 30 A
MAXIMUM CONTINUOUS CURRENT (internally limited)	± 15 A
MINIMUM LOAD INDUCTANCE*	600 µH
SWITCHING FREQUENCY	20 kHz +/-15 %
HEATSINK (BASE) TEMPERATURE RANGE	0° to +65° C, disables if > 65° C
POWER DISSIPATION AT CONT. CURRENT	300 W
OVER-VOLTAGE SHUT-DOWN (self reset)	425 V nominal
BANDWIDTH (load dependent)	2.5 kHz

MECHANICAL SPECIFICATIONS	
POWER CONNECTOR: P3	Screw terminals
SIGNAL CONNECTORS: P1, P2 AMP 748390-6, AMP 748481-6	P1 is a 26 pin high density female D-sub connector and P2 is a 15 pin high density female D-sub connector.
SIZE	8.00 x 5.62 x 1.60 inches 203.2 x 142.9 x 40.7 mm
WEIGHT	2.12 Lb. 0.99 Kg

* Low inductance motors require external inductors.

PIN FUNCTIONS:

CONNECTOR	PIN	NAME	DESCRIPTION / NOTES	I/O
P1	1	+10V @ 3 mA	For customer use	O
	2	SIGNAL GND	Reference ground	SGND
	3	-10V @ 3 mA	For customer use	O
	4	+REF	Differential reference input, maximum $\pm 15V$, 40K input resistance	I
	5	-REF		
	6	Velocity Input	Single ended reference input, external velocity signal, maximum $\pm 10V$, 10K input resistance	I
	7	Encoder Velocity Monitor	1 V = 25 kHz Encoder Frequency	O
	8	Current Monitor	This output represents the actual motor current. Scaling: SW1-3 = OFF, 1 V = 2.1 A motor current SW1-3 = ON, 1 V = 4.2 A motor current	O
	9	Current Reference	This is the command signal to the internal current-loop. The maximum peak current rating of the amplifier always equals 7.25 V at this pin. SW1-3=ON, 7.25V = 30A; SW1-3=OFF, 7.25V = 15A.	O
	10	Reserved		
	11	Inhibit/Enable	This TTL level input signal turns off all power devices of the "H" bridge when pulled to ground with SW1-6=ON. If SW1-6 = OFF pulling this pin to ground will enable the amplifier. This inhibit will cause a fault condition and a red LED.	I
	12	+Inhibit/Enable	If SW1-6=ON, pull P1-12 to ground to inhibit (+) amplifier output and P1-13 to inhibit (-) amplifier output. If SW1-6=OFF, pull P1-12 to ground to enable (+) amplifier output and P1-13 to enable (-) amplifier output. These inputs will NOT cause a fault condition or a red LED.	I
	13	-Inhibit/Enable		
	14	Fault (LED red)	This output activates during short circuit, over-voltage, under voltage, inhibit, over-temperature and power-on reset. A red LED also indicates a fault condition.	O
	15	+5V @ 250Ma	For customer use. Note: the total current on P1-15 and P2-13 combined should not exceed 250 mA.	O
	16	SIGNAL GND	Reference ground	SGND
	17	Controller Power*	Connected to P2-15. For customer use	I
	18	Controller Line 1*	Connected to P2-10. For customer use	I
	19	Controller Line 2*	Connected to P2-11. For customer use	I
	20	Encoder Channel A+**	Differential Encoder Output from P2-4	O
	21	Encoder Channel A-**	Differential Encoder Output from P2-5	
	22	Encoder Channel B+**	Differential Encoder Output from P2-6	O
	23	Encoder Channel B-**	Differential Encoder Output from P2-7	
	24	Encoder Channel I+**	Differential Encoder Output from P2-8	O
	25	Encoder Channel I-**	Differential Encoder Output from P2-9	
	26	Hall Velocity Monitor	1V = 95 Hz Hall Sensor Frequency	O

NOTE: All circuits on connectors P1 and P2 are optically isolated form all circuits on connector P3.

* No connection internal to the amplifier. See block diagram. **The standard product supports a differential encoder. Single ended encoders must use the B30A40-SE1 model. See ordering information below.

PIN FUNCTIONS:

CONNECTOR	PIN	NAME	DESCRIPTION / NOTES	I/O
P2	1	HALL 1	Hall sensor inputs, internal 2K pull-up, logic levels: maximum low level input is 1.5 VDC, minimum high level input is 3.5 VDC	I
	2	HALL 2		
	3	HALL 3		
	4	Encoder Channel A+**	Differential Encoder Input, channel A	I
	5	Encoder Channel A-**		
	6	Encoder Channel B+**	Differential Encoder Input, channel B	I
	7	Encoder Channel B-**		
	8	Encoder Channel I+**	Differential Encoder Input, index mark (Not Required)	I
	9	Encoder Channel I-**		
	10	Controller Line 1*	Connected to P1-18. For customer use.	O
	11	Controller Line 2*	Connected to P1-19. For customer use.	O
	12	Signal GND	Reference ground	SGND
	13	+5V @ 250 mA	For customer use. Note: the total current on P1-15 and P2-13 combined should not exceed 250 mA.	O
	14	TACH	Tachometer Input, 60 K Ω input resistance, \pm 60 V max.	I
	15	Controller power*	Connected to P1-17. For customer use.	O
P3	1	MOTOR A	Motor phase A connection	O
	2	MOTOR B	Motor phase B connection	O
	3	MOTOR C	Motor phase C connection	O
	4	POWER GND	Power ground	PGND
	5	HIGH VOLTAGE	DC power input	I

NOTE: All circuits on connectors P1 and P2 are optically isolated from all circuits on connector P3.

* No connection internal to the amplifier. See block diagram.

**The standard product supports a differential encoder. Single ended encoders must use the B30A40-SE1 model. See ordering information below.

SWITCH FUNCTIONS:**BANK 1**

SWITCH	FUNCTION DESCRIPTION	SETTING	
		ON	OFF
1-1	Test / Offset controls the sensitivity of the "offset" pot. This is used as an on-board reference signal in test mode.	Test	Offset
1-2	Current loop gain	Decrease	Increase
1-3	Current scaling. When OFF, this increases the sensitivity of the current sense thus reducing both peak and continuous current limit by 50%.	100%	50%
1-4	Continuous current reduction	Continuous / peak current limit ratio is 50%	Continuous / peak current limit ratio is 25%
1-5	120/60 degree commutation phasing	120 degree phasing	60 degree phasing
1-6	INHIBIT/ENABLE	P1-11, 12, 13 : INHIBIT	P1-11, 12, 13 : ENABLE

Units are shipped set for ½ current output via SW1-3=off and in the disabled state via SW1-6=off.

BANK 2

SWITCH	FUNCTION DESCRIPTION	SETTING	
		ON	OFF
2-1 †	Encoder Velocity feedback. This connects the internally generated velocity signal from the encoder.	Encoder velocity feedback enabled.	Encoder velocity feedback disabled.
2-2 †	Hall Velocity feedback. This connects the internally generated velocity signal from the Hall sensors.	Hall sensor velocity feedback enabled.	Hall sensor velocity feedback disabled.
2-3 †	Duty Cycle feedback. This connects the internally generated velocity signal from the output stage.	Duty cycle feedback enabled.	Duty cycle feedback disabled.
2-4	Velocity Feedback Polarity	Toggles the polarity of the velocity feedback signal (Encoder or Hall velocity mode only).	
2-5	Loop integrator. This capacitor normally ensures "error-free" operation in velocity mode by reducing the error signal (output of summing amplifier) to zero.	Enables the velocity / voltage loop integrator capacitor.	Disables the velocity / voltage loop integrator capacitor.
2-6	Integrator capacitor. This adjusts the value of the integrator capacitor in the velocity mode.	Increase	Decrease

† Important Note: Amplifier will not operate properly with more than one switch ON due to multiple feedback signals. See block diagram.

POTENTIOMETER FUNCTIONS:

POTENTIOMETER	DESCRIPTION	TURNING CW
Pot 1	Loop gain adjustment in open loop & velocity modes. Turn this pot fully ccw in current mode.	Increases loop gain
Pot 2	Current limit. This potentiometer adjusts both the continuous and peak current limit while maintaining a selected ratio (50%).	Increases current limit
Pot 3	Reference in gain. This potentiometer adjusts the ratio between input signal and output variables (voltage, current, and velocity).	Increases reference input gain
Pot 4	Test / Offset. Used to adjust any imbalance in the input signal or in the amplifier. When SW1-1 (DIP switch) is ON, the sensitivity of this pot is greatly increased allowing it to be used as an on-board signal source for testing purposes. See section "G".	N/A

TEST POINTS FOR POTENTIOMETERS: See section "G".

OPERATING MODE SELECTION:

The following operating modes can be selected by setting the DIP-switches according to the chart in the functional block diagram:

- Current mode
- Open loop mode
- Tachometer mode
- External velocity mode
- HALL velocity mode
- Encoder velocity mode

See section G for more information.

APPLICATION NOTE: For proper operation, P1-6, and P2-14 must be connected to the signal ground if they are not being used.

SET-UP: See section "G" for engineering and installation notes.

CURRENT LIMIT ADJUSTMENTS:

These amplifiers feature separate peak and continuous current limit adjustments. The current limit adjustment Pot 2 adjusts both peak and continuous current limit at the same time. Pot 2 has 12 active turns and one inactive turn on each end and is approximately linear. Thus, to adjust the current limit turn the potentiometer counter-clockwise to zero, then turn clockwise to the appropriate value. In many applications it is sufficient to use only the DIP-switches for current limit adjustments. SW1-3 reduces both peak and continuous current limit by 50% when OFF. SW1-4 reduces only the continuous current limit by 50% when OFF:

SW1-4	CONTINUOUS / PEAK CURRENT LIMIT RATIO
ON	50%
OFF	25%

P1-9 is the input to the internal current amplifier power stage. Since the output current is proportional to P1-9, the adjusted current limit can easily be observed at this pin without connecting the motor. Note that a command signal must be applied to the reference inputs to obtain a reading on P1-9. The maximum peak current value equals 7.25 V at this pin and the maximum continuous current value equals 3.63 V at this pin. If SW3=ON, peak rated amplifier current = 7.25 V. If SW3=OFF, $\frac{1}{2}$ peak rated amplifier current = 7.25 V. Example: using the B30A40 with SW3=ON, 30A=7.25V and with SW3=OFF, 15A=7.25V.

The actual output current can be monitored at pin P1-8.

ORDERING INFORMATION:

Model: B30A40X, B30A40X-SE1

The B30A40X-SE1 is for use with a single ended encoder.

X indicates the current revision letter.

TYPICAL SYSTEM WIRING: See section "G".

MATING CONNECTORS:

Manufacturer: AMP® (Tel: 1-800-522-6752)

Part numbers:

15 Pin plug 748364-1

26 Pin plug 748365-1

Pins 748333-2

Shell Kit (plastic with metal coating)

15 Pin 748677-1

26 Pin 748677-2

MOUNTING DIMENSIONS: See page F-13.

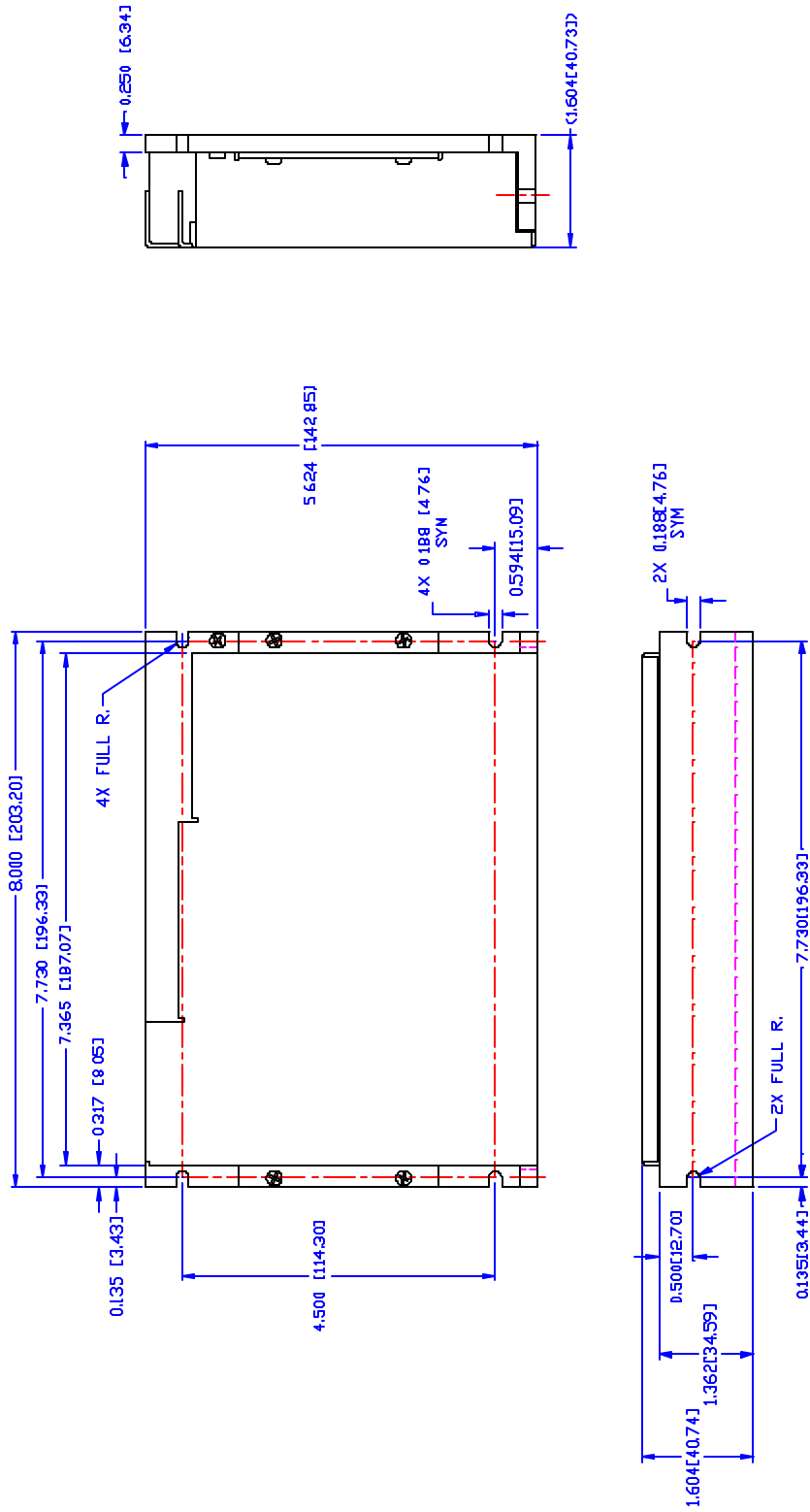

BACKSIDE VIEW

NOTE: DIMENSIONS IN [] ARE IN MM.

REV	DESCRIPTION	DATE	BY
A	CHANGE ADDRESS ON TITLE BLOCK	02/12/02	RB

ADVANCED MOTION CONTROLS PWM SERVO AMPLIFIERS 2805 Calle Terceira, Camarillo, CA 92002	
TITLE MOUNTING DIMENSIONS, B30A40	
SIZE DWG. NO. C	REV A
SCALE: FULL	
SHT. 1 OF 1	

UNLESS OTHERWISE SPECIFIED, DIMENSIONS ARE IN INCHES	
TOLERANCES .XX ± .010 .XXX ± .005	
DO NOT SCALE DRAWING	
DRAWN BY: R. BAUTISTA	DATE: 06/11/98
CHECK BY:	DATE:
DESIGN APPROVED:	DATE:
USED ON	
SR30A SERIES	
SE30A SERIES	
S30A40 SERIES	
B30A40 SERIES	