

B60A-AC SERIES BRUSHLESS SERVO AMPLIFIERS

Model: B60A40AC

FEATURES:

- Surface-mount technology
- Small size, low cost, ease of use
- Optical isolation, see block diagram
- Hall sensor commutation
- DIP switch selectable modes:
current, open loop, tachometer, external velocity, Hall velocity and encoder velocity
- Encoder and Hall velocity monitors
- Four quadrant regenerative operation
- AC supply operation
- Agency Approvals:



BLOCK DIAGRAM:

*Photo for reference only

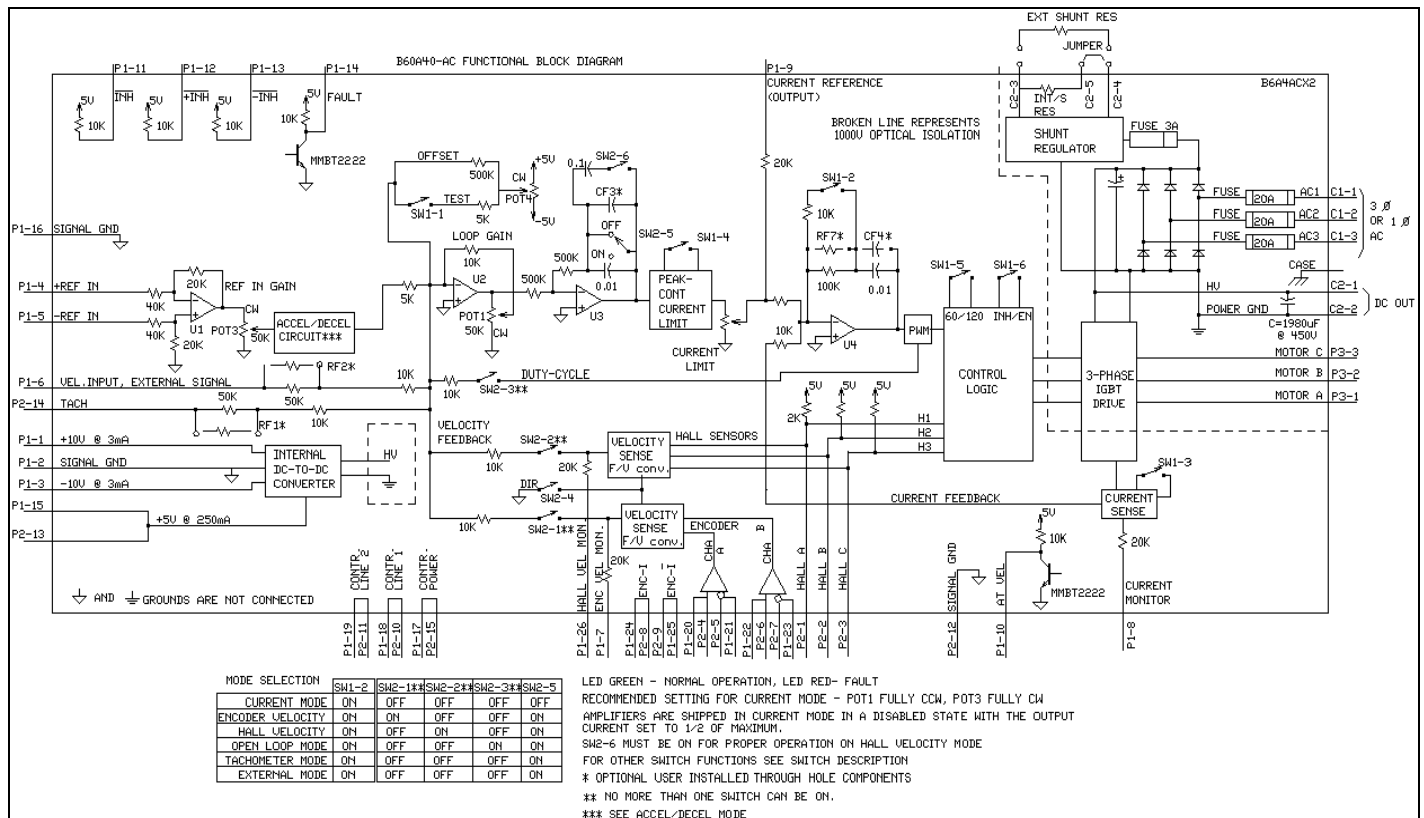

DESCRIPTION: The B60A-AC Series PWM servo amplifiers are designed to drive brushless DC motors at a high switching frequency. They are fully protected against over-voltage, under-voltage, over-current, over-heating and short-circuits. All models interface with digital controllers or can be used as stand-alone drives. They require only a single phase or three-phase AC power supply. A single red/green LED indicates operating status. Loop gain, current limit, input gain and offset can be adjusted using 14-turn potentiometers. The offset adjusting potentiometer can also be used as an on-board input signal for testing purposes when SW1-1 (DIP-switch) is ON.

SPECIFICATIONS:

All B60A40AC specifications are identical to the B60A40 specifications (see B60A40 series data sheets) except for:

	MODEL
POWER STAGE SPECIFICATIONS	B60A40AC
AC SUPPLY VOLTAGE	45-270 VAC, 1 or 3 phase, 50-60 Hz
*CONTINUOUS DC CURRENT AVAILABLE FROM INTERNAL SUPPLY	30 A for three phase AC input
*PEAK DC CURRENT AVAILABLE FROM INTERNAL SUPPLY (MAXIMUM 2 SECONDS)	60 A for three phase AC input
INTERNAL SHUNT RESISTOR	20 Ω @ 100 W
SHUNT SWITCH-ON VOLTAGE**	390 V
BUS CAPACITANCE	1650 μ F
SHUNT FUSE (d=.25 inches, L=1.25 inches)	3 A Motor Delay rated @ 250 VAC
AC LINE FUSES	20 A fast acting rated @ 250 VAC

MECHANICAL SPECIFICATIONS	
AC CONNECTOR: C1	Screw terminals
*DC OUT AND EXTERNAL SHUNT CONNECTOR: C2	Screw terminals
MOTOR CONNECTOR: P3	Screw terminals
SIGNAL CONNECTORS: P1, P2 AMP 748390-6, AMP 748481-6	P1 is a 26 pin high density female D-sub connector and P2 is a 15 pin high density female D-sub connector.
SIZE	9.24 x 6.37 x 6.11 inches 234.7 x 161.8 x 155.2 mm
WEIGHT	11 Lb. 5 Kg

* The internal bus voltage is available on C2 to power DC supply units.

** If the shunt regulator is disabled the shut down voltage is 425 VDC.

These amplifiers contain a rectifier bridge and filter capacitors to generate the DC bus internally from the AC input power. The DC bus voltage is 1.4 times AC voltage (RMS), e.g. 310 VDC from 220 VAC. During braking much of the stored mechanical energy is fed back into the power supply and charges the bus capacitor to a higher voltage. If this voltage reaches the amplifier's over-voltage shutdown point, output current and braking will cease.

To ensure smooth braking of large inertial loads, a built-in "shunt regulator" is provided in the B60A40AC. The shunt regulator will switch on the internal power resistor when the bus voltage reaches 390 VDC. This allows the bus capacitor to discharge and thus lower the bus voltage. During regeneration, the regeneration LED will blink (solid green is non- regeneration mode). An external shunt resistor can be added parallel to the internal resistor (between C2-3 and C2-4). Recommended value is 20 ohms with a minimum 100 W rating. Removing the jumper between C2-4 and C2-5 will disable the internal shunt resistor. If the shunt regulator becomes inoperative the over voltage protection on the amplifier will disable the drive if the regeneration energy causes the bus voltage to exceed 425 VDC.

ORDERING INFORMATION:

Model: B60A40ACX

X indicates current revision letter.

MATING CONNECTORS:

Manufacturer: AMP® (Tel: 1-800-522-6752)

Part numbers:

15 Pin plug	748364-1
26 Pin plug	748365-1

Pins	748333-2
------	----------

Shell Kit (plastic with metal coating)

15 Pin	748677-1
26 Pin	748677-2

TYPICAL SYSTEM WIRING: See section "G".

MOUNTING DIMENSIONS: See page F-18.

B60A SERIES BRUSHLESS SERVO AMPLIFIERS

Model: B60A40

FEATURES:

- Surface-mount technology
- Small size, low cost, ease of use
- Optical isolation, see block diagram
- Hall sensor commutation
- DIP switch selectable modes:
current, open loop, tachometer, external velocity, Hall velocity and encoder velocity
- Encoder and Hall velocity monitors
- Four quadrant regenerative operation
- Agency Approvals:



BLOCK DIAGRAM:

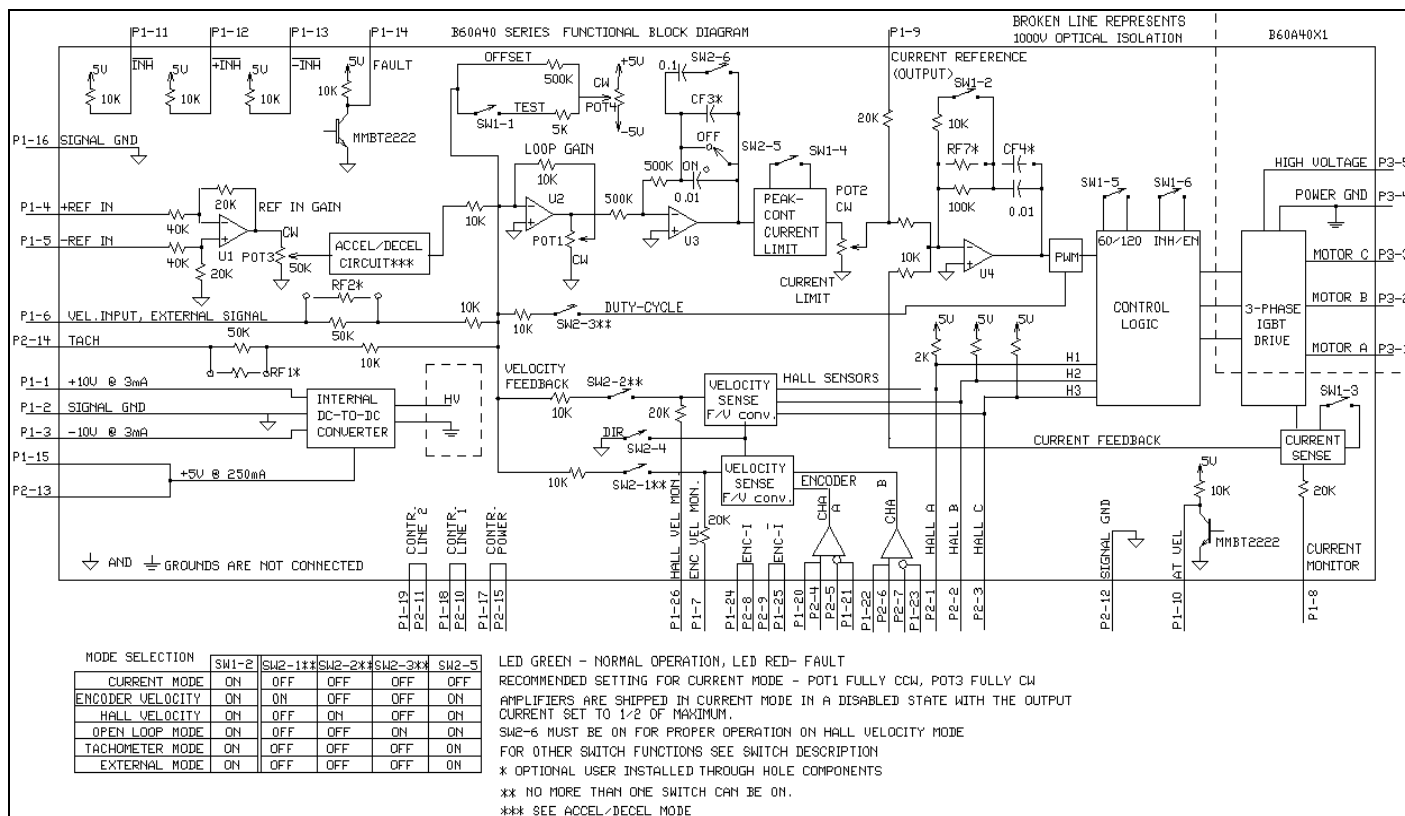

ADVANCED MOTION CONTROLS
 3805 Calle Tecate, Camarillo, CA 93012 Tel: (805) 389-1935, Fax: (805) 389-1165

DESCRIPTION: The B60A Series PWM servo amplifiers are designed to drive brushless DC motors at a high switching frequency. They are fully protected against over-voltage, under-voltage, over-current, over-heating and short-circuits. All models interface with digital controllers or can be used as stand-alone drives. They require only a single unregulated DC power supply. A single red/green LED indicates operating status. Loop gain, current limit, input gain and offset can be adjusted using 14-turn potentiometers. The offset adjusting potentiometer can also be used as an on-board input signal for testing purposes when SW1-1 (DIP-switch) is ON.

SPECIFICATIONS:

	MODEL
POWER STAGE SPECIFICATIONS	B60A40
DC SUPPLY VOLTAGE	60 - 400 VDC
PEAK CURRENT (2 sec. max., internally limited)	± 60 A
MAXIMUM CONTINUOUS CURRENT (internally limited)	± 30 A
MINIMUM LOAD INDUCTANCE*	600 µH
SWITCHING FREQUENCY	15 kHz +/-15 %
HEATSINK (BASE) TEMPERATURE RANGE	0° to +65° C, disables if > 65° C
POWER DISSIPATION AT CONT. CURRENT	600 W
OVER-VOLTAGE SHUT-DOWN (self reset)	425 V nominal
BANDWIDTH (load dependent)	2.5 kHz

MECHANICAL SPECIFICATIONS	
POWER CONNECTOR: P3	Screw terminals
SIGNAL CONNECTORS: P1, P2 AMP 748390-6, AMP 748481-6	P1 is a 26 pin high density female D-sub connector and P2 is a 15 pin high density female D-sub connector.
SIZE	9.24 x 6.31 x 3.50 inches 234.7 x 160.2 x 88.9 mm
WEIGHT	5.64 lbs. 2.56 kg.

* Low inductance motors require external inductors.

PIN FUNCTIONS:

CONNECTOR	PIN	NAME	DESCRIPTION / NOTES	I/O
P1	1	+10V @ 3 mA	For customer use	O
	2	SIGNAL GND	Reference ground	SGND
	3	-10V @ 3 mA	For customer use	O
	4	+REF	Differential reference input, maximum $\pm 15V$, 40K input resistance	I
	5	-REF		
	6	Velocity Input	Single ended reference input, external velocity signal, maximum $\pm 10V$, 60K input resistance	I
	7	Encoder Velocity Monitor	1 V = 25 kHz Encoder Frequency	O
	8	Current Monitor	This output represents the actual motor current. Scaling: SW1-3 = OFF, 1 V = 4.5 A motor current SW1-3 = ON, 1 V = 9 A motor current	O
	9	Current Reference	This is the command signal to the internal current-loop. The maximum peak current rating of the amplifier always equals 7.25 V at this pin. SW1-3=ON, 7.25V = 60A; SW1-3=OFF, 7.25V = 30 A.	O
	10	AT VEL	Open Collector output. Internally pulled up to 5V thru 10K. This output is low, when the speed is within 10% of the commanded speed. See JF6 and JF7 information below.	O
	11	Inhibit/Enable	This TTL level input signal turns off all power devices of the "H" bridge when pulled to ground with SW1-6=ON. If SW1-6 = OFF pulling this pin to ground will enable the amplifier. This inhibit will cause a fault condition and a red LED.	I
	12	+Inhibit/Enable	If SW1-6=ON, pull P1-12 to ground to inhibit (+) amplifier output and P1-13 to inhibit (-) amplifier output. If SW1-6=OFF, pull P1-12 to ground to enable (+) amplifier output and P1-13 to enable (-) amplifier output. These inputs will NOT cause a fault condition or a red LED.	I
	13	-Inhibit/Enable		
	14	Fault (LED red)	This output activates during short circuit, over-voltage, under voltage, inhibit, over-temperature and power-on reset. A red LED also indicates a fault condition.	O
	15	+5V @ 250mA	For customer use. Note: the total current on P1-15 and P2-13 combined should not exceed 250 mA.	O
	16	SIGNAL GND	Reference ground	SGND
	17	Controller Power*	Connected to P2-15. For customer use	I
	18	Controller Line 1*	Connected to P2-10. For customer use	I
	19	Controller Line 2*	Connected to P2-11. For customer use	I
	20	Encoder Channel A+	Differential Encoder Output from P2-4	O
	21	Encoder Channel A-	Differential Encoder Output from P2-5	
	22	Encoder Channel B+	Differential Encoder Output from P2-6	O
	23	Encoder Channel B-	Differential Encoder Output from P2-7	
	24	Encoder Channel I+	Differential Encoder Output from P2-8	O
	25	Encoder Channel I-	Differential Encoder Output from P2-9	
	26	Hall Velocity Monitor	1V = 100 Hz Hall Sensor Frequency	O

NOTE: All circuits on connectors P1 and P2 are optically isolated form all circuits on connector P3.

* No connection internal to the amplifier. See block diagram.

PIN FUNCTIONS:

CONNECTOR	PIN	NAME	DESCRIPTION / NOTES	I/O
P2	1	HALL 1	Hall sensor inputs, internal 2K pull-up, logic levels: maximum low level input is 1.5 VDC, minimum high level input is 3.5 VDC	I
	2	HALL 2		
	3	HALL 3		
	4	Encoder Channel A+	Differential Encoder Input, channel A	I
	5	Encoder Channel A-		
	6	Encoder Channel B+	Differential Encoder Input, channel B	I
	7	Encoder Channel B-		
	8	Encoder Channel I+	Differential Encoder Input, index mark (Not Required)	I
	9	Encoder Channel I-		
	10	Controller Line 1*	Connected to P1-18. For customer use.	O
	11	Controller Line 2*	Connected to P1-19. For customer use.	O
	12	Signal GND	Reference ground	SGND
	13	+5V @ 250 mA	For customer use. Note: the total current on P1-15 and P2-13 combined should not exceed 250 mA.	O
	14	TACH	Tachometer Input, 60 K Ω input resistance, \pm 60 V max.	I
	15	Controller power*	Connected to P1-17. For customer use.	O
P3	1	MOTOR A	Motor phase A connection	O
	2	MOTOR B	Motor phase B connection	O
	3	MOTOR C	Motor phase C connection	O
	4	POWER GND	Power ground	PGND
	5	HIGH VOLTAGE	DC power input	I

NOTE: All circuits on connectors P1 and P2 are optically isolated form all circuits on connector P3.

* No connection internal to the amplifier. See block diagram.

SWITCH FUNCTIONS:**BANK 1**

SWITCH	FUNCTION DESCRIPTION	SETTING	
		ON	OFF
1-1	Test / Offset controls the sensitivity of the "offset" pot. This is used as an on-board reference signal in test mode.	Test	Offset
1-2	Current loop gain	Decrease	Increase
1-3	Current scaling. When OFF, this increases the sensitivity of the current sense thus reducing both peak and continuous current limit by 50%.	100%	50%
1-4	Continuous current reduction	Continuous / peak current limit ratio is 50%	Continuous / peak current limit ratio is 25%
1-5	60/120 degree commutation phasing	120 degree phasing	60 degree phasing
1-6	INHIBIT/ENABLE	P1-11, 12, 13 : INHIBIT	P1-11, 12, 13 : ENABLE

Units are shipped set for ½ current output via SW1-3=off and in the disabled state via SW1-6=off.

BANK 2

SWITCH	FUNCTION DESCRIPTION	SETTING	
		ON	OFF
2-1 †	Encoder Velocity feedback. This connects the internally generated velocity signal from the encoder.	Encoder velocity feedback enabled.	Encoder velocity feedback disabled.
2-2 †	Hall Velocity feedback. This connects the internally generated velocity signal from the Hall sensors.	Hall sensor velocity feedback enabled.	Hall sensor velocity feedback disabled.
2-3 †	Duty Cycle feedback. This connects the internally generated velocity signal from the output stage.	Duty cycle feedback enabled.	Duty cycle feedback disabled.
2-4	Velocity Feedback Polarity	Toggles the polarity of the velocity feedback signal (Encoder or Hall velocity mode only).	
2-5	Loop integrator. This capacitor normally ensures "error-free" operation in velocity mode by reducing the error signal (output of summing amplifier) to zero.	Enables the velocity / voltage loop integrator capacitor.	Disables the velocity / voltage loop integrator capacitor.
2-6	Integrator capacitor. This adjusts the value of the integrator capacitor in the velocity mode.	Increase	Decrease

† Important Note: Amplifier will not operate properly with more than one switch ON due to multiple feedback signals. See block diagram.

POTENTIOMETER FUNCTIONS:

POTENTIOMETER	DESCRIPTION	TURNING CW
Pot 1	Loop gain adjustment in open loop & velocity modes. Turn this pot fully ccw in current mode.	Increases loop gain
Pot 2	Current limit. This potentiometer adjusts both the continuous and peak current limit while maintaining a selected ratio (50%).	Increases current limit
Pot 3	Reference in gain. This potentiometer adjusts the ratio between input signal and output variables (voltage, current, and velocity).	Increases reference input gain
Pot 4	Test / Offset. Used to adjust any imbalance in the input signal or in the amplifier. When SW1-1 (DIP switch) is ON, the sensitivity of this pot is greatly increased allowing it to be used as an on-board signal source for testing purposes. See section "G".	N/A

TEST POINTS FOR POTENTIOMETERS: See section "G".

OPERATING MODE SELECTION:

The following operating modes can be selected by setting the DIP-switches according to the chart in the functional block diagram:

- Current mode
- Open loop mode
- Tachometer mode
- External velocity mode
- HALL velocity mode
- Encoder velocity mode

See section G for more information.

ADJUSTABLE ACCEL/DECEL RATE

The B60A series has built-in acceleration and deceleration when in Hall velocity or Encoder velocity modes. To enable Accel/Decel and the AT VEL output (P1-10), set the jumpers according to the tables.

ACCEL/DECEL	JF8	JF9
Enabled	Not installed	Installed
Disabled	Installed	Not installed

MODE	JF6*	JF7*
HALL Velocity	Not installed	Installed
Encoder Velocity	Installed	Not installed

*Based on the mode of operation, JF6 and JF7 must be configured as shown above for proper operation of the AT VEL (P1-10) function.

JF6-JF9 are jumper locations on the PCB. These jumper locations are silk-screened on the PCB for easy identification.

The acceleration and deceleration rates can be set independently using through-hole resistors at locations RF3, RF4, RF5 and RF6 (see table below). The rates are based on + or – 10 Volts to the Reference inputs. The “Time” listed in the table below is the time it takes to reach the 10-Volt input. The ramping rates are linear with respect to time. For example, if the input were only 5 Volts, the time to ramp to this voltage would be half the time to ramp to 10 Volts. These locations are silk-screened on the PCB for easy identification.

Time (Seconds)	Acceleration		Deceleration	
	RF3 (Ohms)	RF4 (Ohms)	RF6 (Ohms)	RF5 (Ohms)
1	50K	50K	50K	50K
2	50K	20K	50K	20K
3*	10K	10K	10K	10K
4	500K	20K	500K	20K
5	50K	5K	50K	5K
6	500K	10K	500K	10K
7	50K	2K	50K	2K
8	50K	1K	50K	1K
9	20K	0.1K	20K	0.1K
10	100K	0.1K	100K	0.1K

* = Default setting

APPLICATION NOTE: For proper operation, P1-6, and P2-14 must be connected to the signal ground if they are not being used.

SET-UP: See section "G" for engineering and installation notes.

CURRENT LIMIT ADJUSTMENTS:

These amplifiers feature separate peak and continuous current limit adjustments. The current limit adjustment Pot 2 adjusts both peak and continuous current limit at the same time. Pot 2 has 12 active turns and one inactive turn on each end and is approximately linear. Thus, to adjust the current limit turn the potentiometer counter-clockwise to zero, then turn clockwise to the appropriate value. In many applications it is sufficient to use only the DIP-switches for current limit adjustments. SW1-3 reduces both peak and continuous current limit by 50% when OFF. SW1-4 reduces only the continuous current limit by 50% when OFF:

SW1-4	CONTINUOUS / PEAK CURRENT LIMIT RATIO
ON	50%
OFF	25%

P1-9 is the input to the internal current amplifier power stage. Since the output current is proportional to P1-9, the adjusted current limit can easily be observed at this pin without connecting the motor. Note that a command signal must be applied to the reference inputs to obtain a reading on P1-9. The maximum peak current value equals 7.25 V at this pin and the maximum continuous current value equals 3.63 V at this pin. If SW3=ON, peak rated amplifier current = 7.25 V. If SW3=OFF, ½ peak rated amplifier current = 7.25 V. Example: using the B60A40 with SW3=ON, 60A=7.25V and with SW3=OFF, 30A=7.25V.

The actual output current can be monitored at pin P1-8.

ORDERING INFORMATION:

Model: B60A40X

X indicates the current revision letter.

TYPICAL SYSTEM WIRING: See section "G".

MATING CONNECTORS:

Manufacturer: AMP® (Tel: 1-800-522-6752)

Part numbers:

15 Pin plug	748364-1
26 Pin plug	748365-1

Pins	748333-2
------	----------

Shell Kit (plastic with metal coating)

15 Pin	748677-1
26 Pin	748677-2

