

## BX25A20AC SERIES BRUSHLESS SERVO AMPLIFIERS

### Model: BX25A20AC

### 120VAC Single Supply Operation

**FEATURES:**

- Surface-mount technology
- Small size, low cost, ease of use
- Built-in shunt regulator
- DIP switch/jumper selectable modes: current, open loop, tachometer, HALL velocity and encoder velocity
- Latching/Non Latching fault, active hi/active low fault and inhibit /enable are dip switch selectable
- Four quadrant regenerative operation
- Agency approvals:

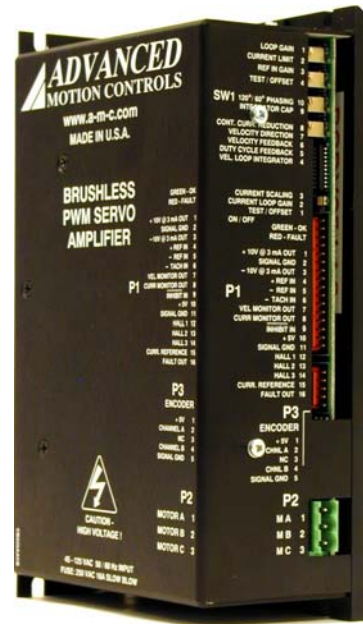

**BLOCK DIAGRAM:**

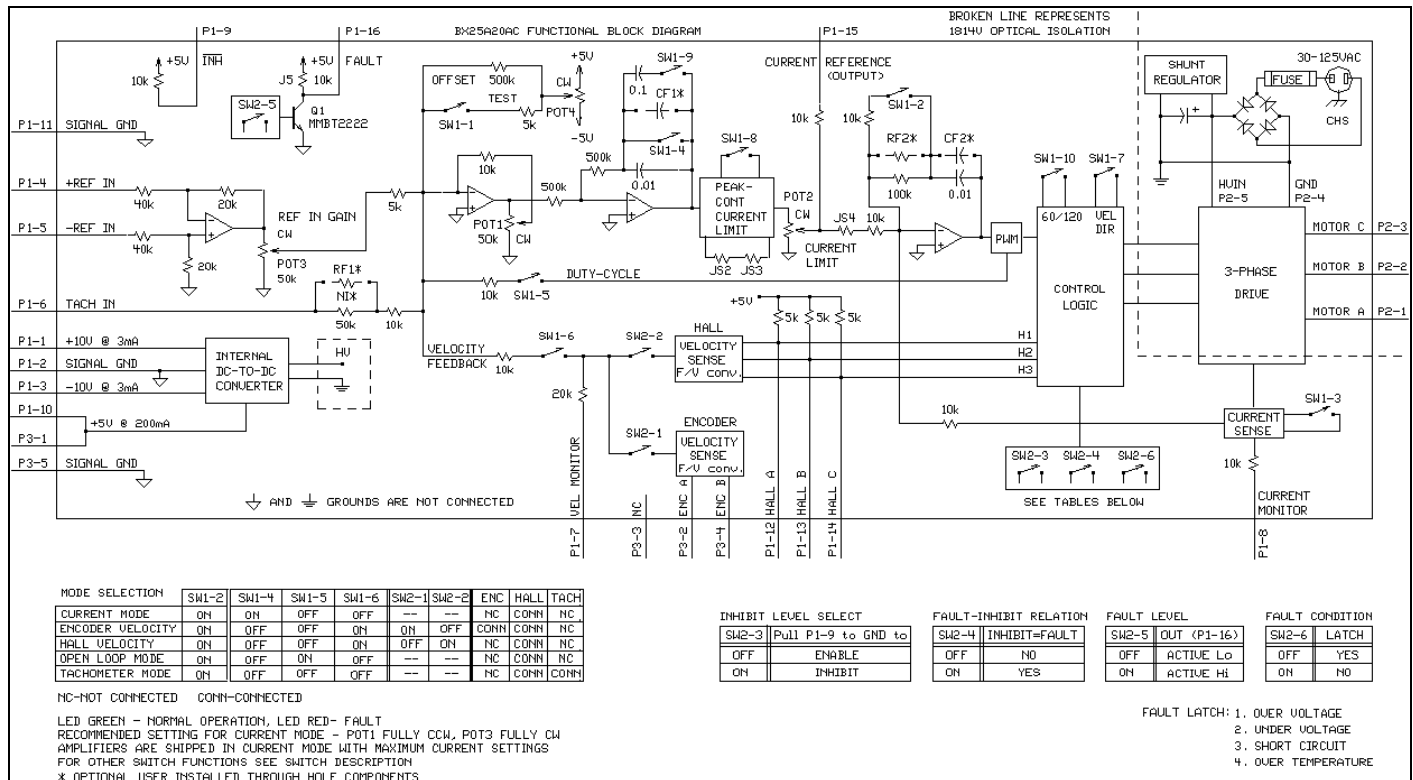

**DESCRIPTION:** The BX25A20AC Series PWM servo amplifiers are designed to drive brushless DC motors at a high switching frequency. The BX25A20AC is fully protected against over-voltage, over-current, over-heating and short-circuits. This model interfaces with digital controllers or can be used as a stand-alone drive and requires only a single unregulated AC power supply. A single red/green LED and a single digital output indicate operating status. Loop gain, current limit, input gain and offset can be adjusted using 14-turn potentiometers. The offset adjusting potentiometer can also be used as an on-board input signal for testing purposes, when SW1 (DIP switch) is ON.

**SPECIFICATIONS:**

All BX25A20AC specifications are identical to the BX25A20 specifications (see BX30A series data sheets) except for:

	MODEL
<b>POWER STAGE SPECIFICATIONS</b>	<b>BX25A20AC</b>
SINGLE PHASE AC SUPPLY VOLTAGE	45 - 140 VAC @ 50-60 Hz
SHUNT RESISTOR	10 Ω @ 50 W
SHUNT SWITCH-ON VOLTAGE*	195 VDC
BUS CAPACITANCE	3600 μF
SHUNT FUSE (d=.25 inches, L=1.25 inches)	3 A Motor Delay rated @ 250 VAC
BUS FUSE (5x20 mm)	16 A slow-blow rated @ 250 VAC

<b>MECHANICAL SPECIFICATIONS</b>	
POWER CONNECTOR	Quick Disconnect
SIGNAL CONNECTOR	Molex connector
SIZE	7.35 x 4.23 x 2.45 inches 186.7 x 107.4 x 62.2 mm
WEIGHT	2.5 lb. 1.14 kg

\* If the shunt regulator is disabled the shut down voltage is 205 VDC.

These amplifiers contain a rectifier bridge and filter capacitors to generate the DC bus internally from the AC input power. The DC bus voltage is 1.4 times AC voltage (RMS), e.g. 170 VDC from 120 VAC. During braking much of the stored mechanical energy is fed back into the power supply and charges the output capacitor to a higher voltage. If the charge reaches the amplifier's over-voltage shutdown point, output current and braking will cease. To ensure smooth braking of large inertial loads, a built-in "shunt regulator" is provided in this model. The shunt regulator will switch-on the internal power resistor when the bus voltage exceeds 195 VDC. This resistor then dissipates the extra energy of the DC bus.

**ORDERING INFORMATION:**

Model: BX25A20ACX

X (at the end) indicates the current revision letter.

**TYPICAL SYSTEM WIRING:** See section "G".

**MOUNTING DIMENSIONS:** See page F-11.



**DESCRIPTION:** The BX30A Series PWM servo amplifiers are designed to drive brushless DC motors at a high switching frequency. They are fully protected against over-voltage, over-current, over-heating and short-circuits. All models interface with digital controllers or can be used as stand-alone drives. They require only a single unregulated DC power supply. A single red/green LED indicates operating status. Loop gain, current limit, input gain and offset can be adjusted using 14-turn potentiometers. The offset adjusting potentiometer can also be used as an on-board input signal for testing purposes when SW1 (DIP switch) is ON. These models can use quadrature encoder inputs or Hall sensors for velocity control.

**SPECIFICATIONS:**

	MODEL
<b>POWER STAGE SPECIFICATIONS</b>	<b>BX25A20</b>
DC SUPPLY VOLTAGE	60 - 200 V
PEAK CURRENT (2 sec. Max., internally limited)	± 25 A
MAX. CONTINUOUS CURRENT (internally limited)	± 12.5 A
MINIMUM LOAD INDUCTANCE*	250 µH
SWITCHING FREQUENCY	22 kHz ± 15%
HEATSINK (BASE) TEMPERATURE RANGE	0° to +65° C, disables if > 65° C
POWER DISSIPATION AT CONTINUOUS CURRENT	125 W
OVER-VOLTAGE SHUT-DOWN (self reset)	205 V
BANDWIDTH (load dependent)	2.5 kHz

MECHANICAL SPECIFICATIONS	
POWER CONNECTOR	Screw Terminals
SIGNAL CONNECTOR	Molex connector
SIZE	7.35 x 4.40 x 1.45 inches
	186.7 x 111.7 x 36.8 mm
WEIGHT	1.5 lb.
	0.68 kg

\* Low inductance motors require external inductors.

**PIN FUNCTIONS:**

CONNECTOR	PIN	NAME	DESCRIPTION / NOTES	I/O
P1	1	+10V @ 3 mA OUT	For customer use	O
	2	SIGNAL GND	Reference ground	SGND
	3	-10V @ 3 mA OUT	For customer use	O
	4	+REF IN	Differential reference input, Maximum $\pm 15$ V, 40K input resistance	I
	5	-REF IN		
	6	-TACH IN	Tachometer input, max. $\pm 60$ VDC, 60K input resistance	I
	7	VELOCITY MONITOR OUT	Velocity monitor, 1 V = 25 kHz encoder frequency 1V=125 Hz Hall sensor frequency	O
	8	CURRENT MONITOR OUT	Proportional to motor current; 1 V = 2 A when SW1-3 is off; , 1 V = 4 A when SW1-3 is on	O
	9	INHIBIT IN	This TTL level input signal turns off all power devices of the "H" bridge when pulled to ground with SW2-3=ON. If SW2-3 = OFF pulling this pin to ground will enable the amplifier. Inhibit will cause a fault condition and a red led if SW2-4 is on.	I
	10	+5V @ 200 mA	For customer use, power for HALL sensors, +5V @ 200 mA Note: the total current on P1-10 and P3-1 combined should not exceed 200 mA.	O
	11	SIGNAL GND	Reference ground for the Hall sensors	SGND
	12	HALL A	HALL sensor inputs, logic levels, Internal 5 K $\Omega$ pull-up. Maximum low level input is 1.5 V, minimum high level input is 3.5 V	I
	13	HALL B		
	14	HALL C		
	15	CURRENT REFERENCE OUT	Monitors the input signal connected directly to the internal current amplifier. 7.25 V = max peak current. See current limit adjustment information below.	O
	16	FAULT OUT (LED red)	Transistor output. Open collector. Contact factory for higher pull up voltages. This output can sink or source 20 mA max. Active during output short circuit, over-voltage, over temperature and power-up reset. Fault condition indicated by red LED. Inhibit condition will indicate a fault if SW2-4 is on. Active high or low fault selected by SW2-5. Latching faults/non-latching faults selectable with SW2-6.	O
P2	1	MOTOR A	Motor phase A connection	O
	2	MOTOR B	Motor phase B connection	O
	3	MOTOR C	Motor phase C connection	O
	4	POWER GND	Power ground	PGND
	5	HIGH VOLT	DC power input	I
P3 ENCODER	1	+5V @ 200 mA	For customer use, power for the encoder, +5V @ 200 mA Note: the total current on P1-10 and P3-1 combined should not exceed 200 mA.	O
	2	ENC A	5V CMOS level quadrature encoder input	I
	3	NC	Not connected	
	4	ENC B	5V CMOS level quadrature encoder input	I
	5	SIGNAL GND	Reference gnd for encoder	SGND

**SWITCH FUNCTIONS:**

SWITCH	FUNCTION DESCRIPTION	SETTING	
		ON	OFF
1	Test / Offset. Sensitivity of the "offset" pot. Used as an on-board reference signal in test mode.	Test	Offset
2	Current loop gain	Decrease	Increase
3	Current scaling. When OFF, increases sensitivity of current sense thus reducing both peak and continuous current limit by 50%.	100%	50%
4	Loop integrator. This capacitor normally ensures "error-free" operation in velocity mode by reducing the error signal (output of summing amplifier) to zero.	Shorts out the velocity/voltage loop integrator capacitor	Velocity/voltage loop integrator operating
5	Internal duty-cycle feedback for open loop mode	On	Off
6	Velocity feedback. Connects the internally generated velocity signal. SW2-1 must also be on for encoder velocity mode and SW2-2 for Hall velocity mode.	On	Off
7	Velocity direction. Changes the polarity of the velocity monitor signal.		
8	Continuous current reduction. Reduces continuous current limit by 50%.	Continuous / peak current limit ratio is 50%	Continuous / peak current limit ratio is 25%
9	Integrator capacitor. Adjusts the value of the integrator capacitor in velocity mode.	Increase	Decrease
10	60/120 degree commutation phasing setting	120 degree phasing	60 degree phasing

SWITCH	FUNCTION DESCRIPTION	SETTING	
		ON	OFF
2-1 †	Encoder Velocity feedback. This connects the internally generated velocity signal from the encoder. For EVM SW6 must also be on.	Encoder velocity feedback enabled.	Encoder velocity feedback disabled.
2-2 †	Hall Velocity feedback. This connects the internally generated velocity signal from the Hall sensors. For HVM SW6 must also be on.	Hall sensor velocity feedback enabled.	Hall sensor velocity feedback disabled.
2-3	INHIBIT/ENABLE	P1-9 pull to ground to INHIBIT	P1-9, pull to ground to ENABLE
2-4	INHIBIT=FAULT	Inhibit condition will cause a fault level on P1-16 and a red LED	Inhibit condition will not cause a fault level on P1-16 or a red LED
2-5	ACTIVE FAULT LEVEL OF P1-16	ACTIVE HIGH	ACTIVE LOW
2-6	FAULT LATCH	Non Latching faults, once the fault clears the unit will enable again	Latching faults, fault condition must be removed and power must be cycled or inhibit line toggled to clear any fault condition

† Important Note: Amplifier will not operate properly with more than one switch ON due to multiple feedback signals. See block diagram.

**POTENTIOMETER FUNCTIONS:**

POTENTIOMETER	DESCRIPTION	TURNING CW
Pot 1	Loop gain adjustment in open loop & velocity modes. Turn this pot fully ccw in current mode.	Increases loop gain
Pot 2	Current limit. It adjusts both continuous and peak current limit maintaining selected ratio (50%).	Increases current limit
Pot 3	Reference gain. It adjusts the ratio between input signal and output variables (voltage, current, velocity).	Increases reference input gain
Pot 4	Test / Offset. Used to adjust any imbalance in the input signal or in the amplifier. When SW1 (DIP switch) is ON, the sensitivity of this pot is greatly increased thus it can be used as an on-board signal source for testing purposes. See section "G".	N/A

**TEST POINTS FOR POTENTIOMETERS:** See section "G".

**OPERATING MODE SELECTION:**

These modes can be selected by the DIP switches according to the chart in the functional block diagram:

- Current mode
- Open loop mode
- Tachometer mode
- Encoder velocity mode
- Hall Velocity mode

See section "G" for more information.

**SET-UP:** See section "G" for engineering and installation notes.

**CURRENT LIMIT ADJUSTMENTS:**

These amplifiers feature separate peak and continuous current limit adjustments. The current limit adjustment Pot 2 adjusts both peak and continuous current limit simultaneously. It has 12 active turns plus 1 inactive turn at each end and is approximately linear. Thus, to adjust the current limit turn the potentiometer fully counter-clockwise, then turn clockwise to the appropriate value.

In many applications it is sufficient to use only the DIP switches for current limit adjustments. SW3 reduces both peak and continuous current limit by 50% when OFF. SW8 reduces only the continuous current limit by 50% when OFF:

SW8	CONTINUOUS / PEAK CURRENT LIMIT RATIO
ON	50%
OFF	25%

P1-15 is the input to the internal current amplifier power stage. Since the output current is proportional to P1-15, the adjusted current limit can easily be observed at this pin without connecting the motor. Note that a command signal must be applied to the reference inputs to obtain a reading on P1-15. The maximum peak current value equals 7.25 V at this pin and the maximum continuous current value equals 3.63 V at this pin. If SW3=ON, peak rated amplifier current = 7.25 V. If SW3=OFF,  $\frac{1}{2}$  peak rated amplifier current = 7.25 V. Example: using the BX25A20 with SW3=ON, 25A=7.25V and with SW3=OFF, 12.5A=7.25V.

The actual current can be monitored at pin P1-8.

#### **VELOCITY DIRECTION SWITCH (SW1-7):**

In either Hall or Encoder Velocity Mode, the velocity feedback direction switch (SW1-7) allows the user to select the correct feedback polarity for proper operation. In one switch position, the motor will operate properly, but the opposite switch position will cause the motor to run away due to positive feedback. The correct switch position will not be the same for all applications. It may be either ON or OFF depending on wiring combination.

NOTE: If any of the BX25A20AC or BX30A series servo amplifiers are being used as a direct replacement for your B25A20AC, BE25A20AC, B30A or BE30A series in Hall or Encoder Velocity Mode, SW1-7 MUST be set in the OPPOSITE position for proper operation. Otherwise, the motor will run away.

#### **ORDERING INFORMATION:**

Model: BX25A20X

X (at the end) indicates the current revision letter.

**TYPICAL SYSTEM WIRING:** See section "G".

**MOUNTING DIMENSIONS:** See page F-35.

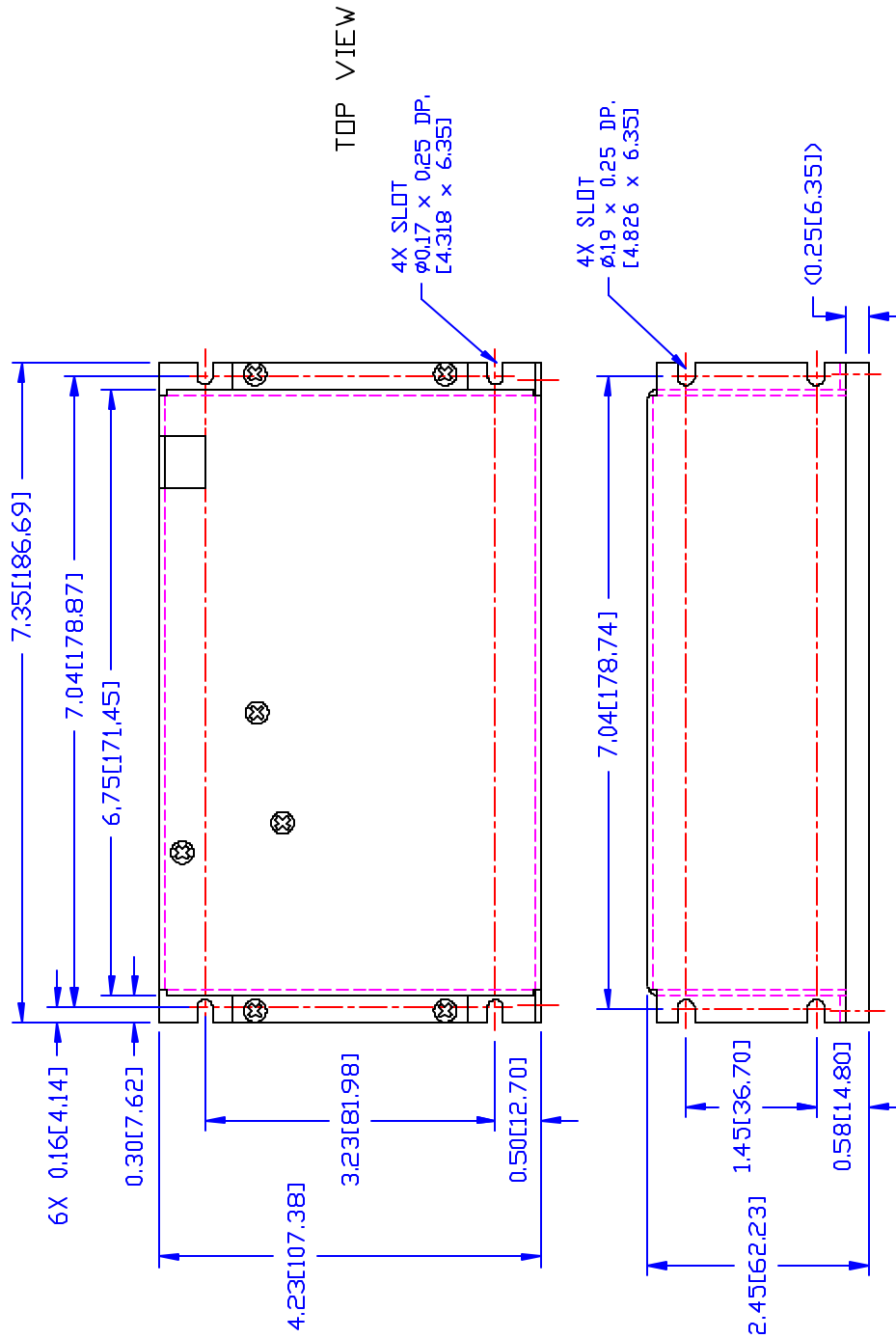

BACKSIDE VIEW

TOP VIEW

B	ADD BX25A20AC TO USED ON COLUMN	01/25/02	RB
A	UPDATE DWG. FORMAT & PICTORIAL	08/22/96	RB
REV	DESCRIPTION	DATE	BY



• PWM SERVO AMPLIFIERS •  
3805 Calle Tecate, Cananillo, CA 93012

TITLE  
MOUNTING DIMENSIONS  
B25A-AC & 30A-AC SERIES

SIZE DWG. NO.  
B MB25AAC

SCALE: NONE  
SHT. 1 OF 1

UNLESS OTHERWISE SPECIFIED: DIMENSIONS ARE IN INCHES TOLERANCES XX ± .010 XXX ± .005	
DO NOT SCALE DRAWING	
DRAWN BY: R. BAUTISTA	DATE: 10/06/95
CHECK BY:	DATE:
DESIGN APPROVED:	DATE:
USED ON	
BX25A20AC SERIES	
BE25A20AC SERIES	
B25A20AC SERIES	
BD25A-AC SERIES	
30A-AC SERIES	

NOTE: DIMENSIONS IN [ ] ARE IN MM.