

DIGIFLEX® DIGITAL SERVO DRIVES MODEL: DQ111EE30A40LDC

WITH **SynqNet™** INTERFACE

FEATURES:

- Fully digital, state-of-the-art DSP design
- Space Vector Modulation technology
- 20kHz Digital current loop with programmable gain settings
- Hall sensor + encoder or encoder-only based commutation
- Surface-mount technology
- Small size, low cost, ease of use

- SynqNet™ motion control network interface
- Windows95/98/2000/ME/NT© based setup software for setup via SynqNet™ interface
- Operates in torque mode with programmable gain settings and current limiting

- 2 programmable isolated digital inputs
- 4 programmable isolated digital outputs
- 14-bit reference input or programmable analog input
- 2 high-speed differential inputs (high-speed capture, secondary encoder)
- 2 high-speed differential outputs (step&dir, divide-by-N)
- Dedicated, isolated E-stop, positive and negative limits, and home inputs

- Separate logic supply
- Four quadrant regenerative operation
- Integrated shunt regulator
- Bi-color LED status indicator
- Extensive built-in protection against:
 - over-voltage (programmable)
 - under-voltage (programmable)
 - short-circuit: phase-phase, phase-ground
 - over-current
 - over-temperature



* Picture for reference only

ADVANCED MOTION CONTROLS
 3805 Calle Tecate, Camarillo, CA 93012
 Tel: (805) 389-1935, Fax: (805) 389-1165
<http://www.a-m-c.com>

BLOCK DIAGRAM:

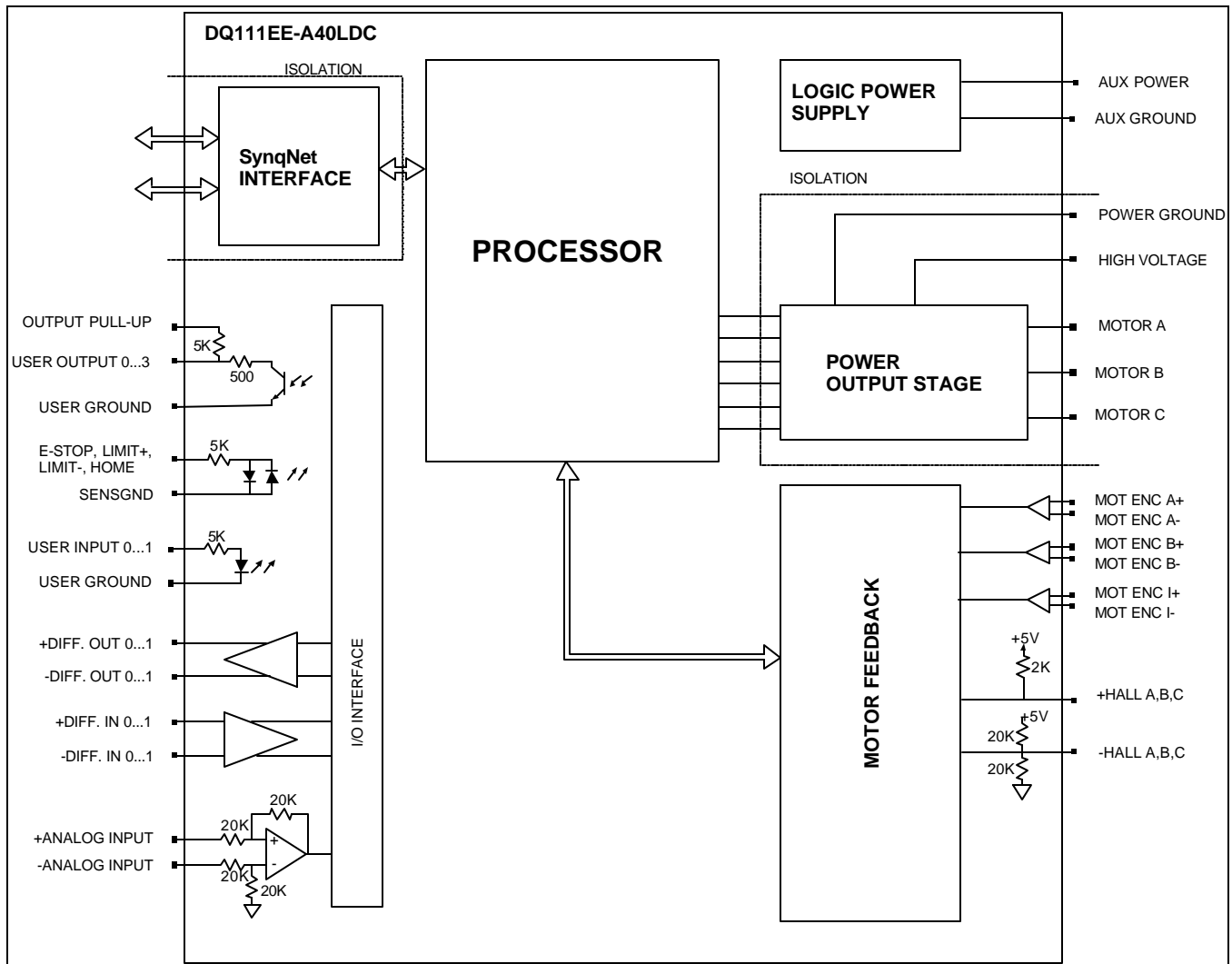

DESCRIPTION:

The DQ111EE Series digital PWM servo drives are designed to drive brushed and brushless servomotors. These fully digital drives operate in torque mode and employ Space Vector Modulation (SVM), which results in higher bus voltage utilization and reduced heat dissipation. The command source can be generated internally or can be supplied externally. In addition to motor control, these drives feature dedicated and programmable digital and analog inputs and outputs to enhance interfacing with external controllers and devices.

DQ111EE Series drives feature a SynqNet™ interface for high-speed digital command operation in networked applications. Drive commissioning can be accomplished through a fully graphical Windows© based application via the SynqNet interface™.

More information about SynqNet™ can be obtained at <http://www.synqnet.org>.

All drive and motor parameters are stored in non-volatile memory.

SPECIFICATIONS:

POWER STAGE SPECIFICATIONS	DQ111EE30A40LDC
DC SUPPLY VOLTAGE	60...400 VDC
PEAK CURRENT	30A (21.2Arms)
MAXIMUM CONTINUOUS CURRENT	15A (10.6Arms)
MINIMUM LOAD INDUCTANCE	600 μ H
SWITCHING FREQUENCY	20 kHz
HEATSINK (BASEPLATE) TEMPERATURE RANGE	0 to 65 °C, disables at 65 °C
POWER DISSIPATION AT CONTINUOUS CURRENT	300W
MIN. UNDER VOLTAGE SHUTDOWN	60 VDC
MAX. OVER-VOLTAGE SHUTDOWN	425 VDC
LOGIC SUPPLY VOLTAGE	20...30 VDC

MECHANICAL SPECIFICATIONS	
POWER CONNECTOR: P1	Screw terminal
MOTOR FEEDBACK CONNECTOR: CN4*	15-pin high density female D-sub
I/O CONNECTOR: CN3*	26-pin high density female D-sub
SYNQNET™ CONNECTOR: CN1, CN2*	8-pin RJ45
SIZE	8.00 x 5.69 x 1.92 inches 203.2 x 144.4 x 48.7 mm
WEIGHT	

* Mating connectors are not included.

PIN FUNCTIONS:

P1 - Motor and Power Connector:

CONNECTOR	PIN	NAME	DESCRIPTION	I/O
P1	1	MA	Motor phase A	O
	2	MB	Motor phase B	O
	3	MC	Motor phase C	O
	4	PGND	Power ground	GND
	5	HV IN	DC motor supply	I
	6	GND AUX	Logic supply ground	GND
	7	PWR AUX	Logic supply power	I

CN4 - Motor Feedback Connector:

CONNECTOR	PIN	NAME	DESCRIPTION	I/O
CN4	1	+Hall A	Commutation sensor inputs. Internal 2K pull-up to +5VDC. Can be used with single ended or differential Hall sensors.	I
	2	+Hall B		I
	3	+Hall C		I
	4	MOT ENC A+	Differential Encoder Input. For single ended encoder signals, leave the A-terminal open.	I
	5	MOT ENC A-		I
	6	MOT ENC B+	Differential Encoder Input. For single ended encoder signals, leave the B-terminal open.	I
	7	MOT ENC B-		I
	8	MOT ENC I+	Differential Encoder Input. For single ended encoder signals, leave the I-terminal open.	I
	9	MOT ENC I-		I
	10	-Hall A*	See CN4-1. Leave open in case of single ended Hall sensors.	I
	11	-Hall B*	See CN4-2. Leave open in case of single ended Hall sensors.	I
	12	SGND	Signal ground	SGND
	13	+5V OUT	+5V @ 250mA max. Short-circuit protected.	O
	14	Reserved		
	15	-Hall C*	See CN4-3. Leave open in case of single ended Hall sensors.	I

CN3 – I/O Connector:

CONNECTOR	PIN	NAME	DESCRIPTION	I/O
CN3	1	USER OUTPUT 0	Programmable digital output. Isolated, 24VDC, referenced to USER GND	O
	2	USER OUTPUT 1	Programmable digital output. Isolated, 24VDC, referenced to USER GND	O
	3	USER GND	Ground reference for user outputs and inputs.	GND
	4	USER OUTPUT 2	Programmable digital output. Isolated, 24VDC, referenced to USER GND	O
	5	USER OUTPUT 3	Programmable digital output. Isolated, 24VDC, referenced to USER GND	O
	6	SGND	Digital ground	SGND
	7	+ DIFF. INPUT 0	Differential input. 5V TTL., non-isolated. Programmable function: capture, encoder input	I
	8	- DIFF. INPUT 0		I
	9	OUTPUT PULL-UP	5K Pull-up for user outputs.	I
	10	E-STOP	Emergency stop input. Isolated, 24VDC range. Referenced to sensor ground (SENSGND).	I
	11	LIMIT +	Positive limit input. Isolated, 24VDC range. Referenced to sensor ground (SENSGND).	I
	12	LIMIT -	Negative limit input. Isolated, 24VDC range. Referenced to sensor ground (SENSGND).	I
	13	HOME	Home switch input. Isolated, 24VDC range. Referenced to sensor ground (SENSGND).	I
	14	USER INPUT 0	Programmable digital input. Isolated, 24VDC, referenced to USER GND	I
	15	USER INPUT 1	Programmable digital input. Isolated, 24VDC, referenced to USER GND	I
	16	SENSGND	Sensor ground. Used with E-stop, limit +, limit -, and home inputs.	GND
	17	+ DIFF. INPUT 1	Differential input. 5V TTL., non-isolated. Programmable function: capture, encoder input	I
	18	- DIFF. INPUT 1		I
	19	SGND	Digital ground	SGND
	20	+ DIFF. OUTPUT 0	Differential output. 5V TTL., non-isolated. Programmable function: step&dir, divide-by-N	I
	21	- DIFF. OUTPUT 0		I
	22	+ DIFF. OUTPUT 1	Differential output. 5V TTL., non-isolated. Programmable function: step&dir, divide-by-N	I
	23	- DIFF. OUTPUT 1		I
	24	+ANALOG IN	Programmable, differential analog input, +/- 10V range, 14-bit.	I
	25	-ANALOG IN		I
	26	AGND	Analog ground.	AGND

CN1 – SYNQNET™ INTERFACE:

CONNECTOR	PIN	NAME	DESCRIPTION	I/O
CN1	1	RD+	100BaseT receiver	I
	2	RD-		I
	3	TD+	100BaseT transmitter	O
	6	TD-		O
	4, 5, 7, 8	N/C	Not connected	

CN2 – SYNQNET™ INTERFACE:

CONNECTOR	PIN	NAME	DESCRIPTION	I/O
CN2	1	TD+	100BaseT transmitter	O
	2	TD-		O
	3	RD+	100BaseT receiver	I
	6	RD-		I
	4, 5, 7, 8	N/C	Not connected	

ORDERING INFORMATION:

Standard model: DQ111EE30A40LDCX

X indicates the current revision letter.

MOUNTING DIMENSIONS:

