

## S60A40AC SERIES BRUSHLESS SERVO AMPLIFIERS

### Model: S60A40AC

**FEATURES:**

- Surface-mount technology
- Small size, low cost, ease of use
- Optical isolation, see block diagram
- Sinusoidal drive and current control
- Four quadrant regenerative operation
- AC supply operation
- Agency approvals:



**BLOCK DIAGRAM:**

\*Photo for reference only

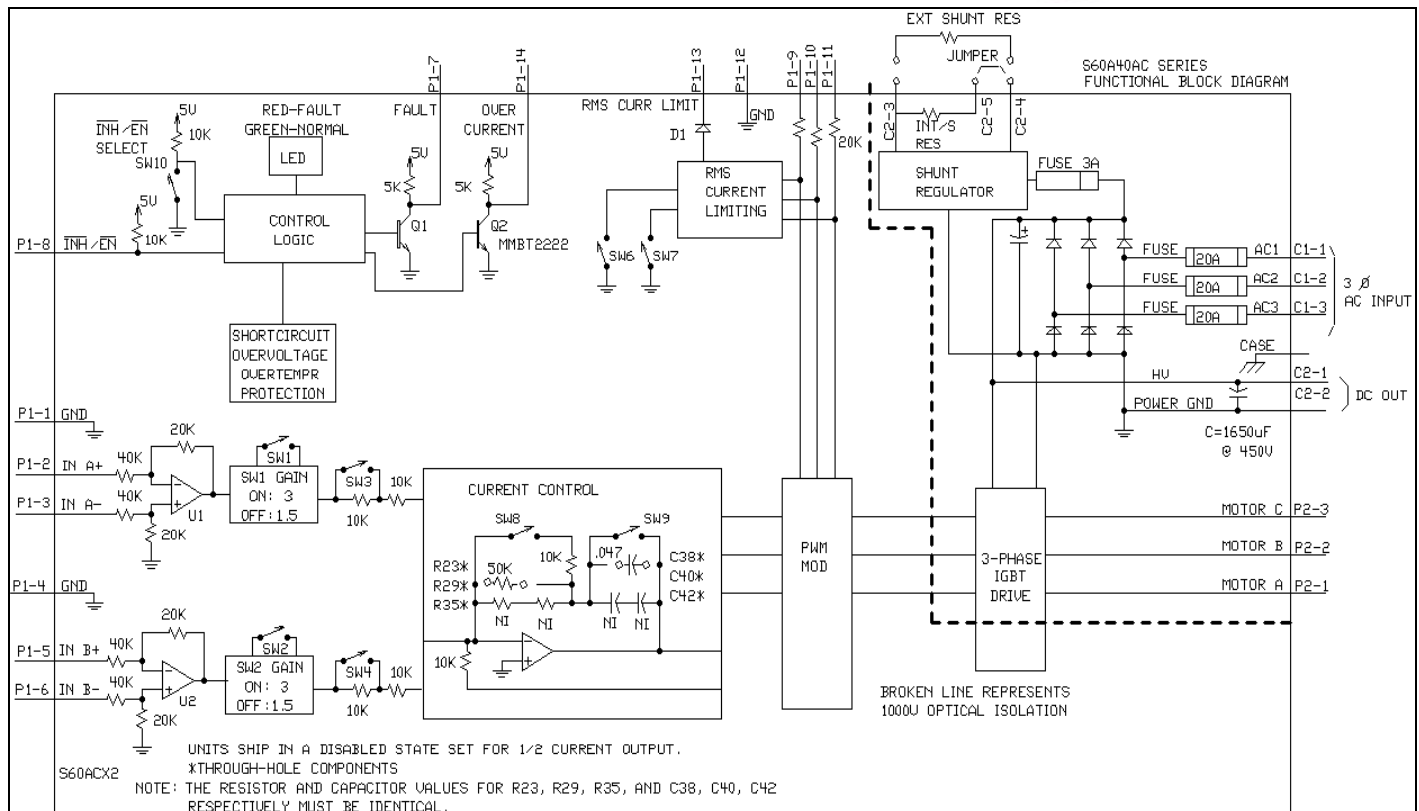

**ADVANCED MOTION CONTROLS**  
3805 Calle Tecate, Camarillo, CA 93012 Tel: (805) 389-1935, Fax: (805) 389-1165

**DESCRIPTION:** The S60A40AC Series PWM servo amplifiers are designed to drive three phase brushless motors with sine wave current at a high switching frequency. They require two sinusoidal command signals with a 120-degree phase shift (external commutation). The phase angle must correspond to the position of the motor rotor, while the signal amplitude controls the motor torque. All models typically interface directly with digital controllers. The amplifiers are fully protected against over-voltage, under-voltage, over-current, over-heating, and short-circuits. The S60A40AC requires a single or three-phase AC power supply. A red/green LED and two digital outputs indicate operating status. All signal inputs and outputs are optically isolated from the power section to eliminate the need for a transformer coupled power supply.

**SPECIFICATIONS:**

All S60A40AC specifications are identical to the S60A40 specifications (see S60A series data sheets) except for:

	<b>MODEL</b>
<b>POWER STAGE SPECIFICATIONS</b>	<b>S60A40AC</b>
AC SUPPLY VOLTAGE	45-270 VAC, 3 phase, 50-60 Hz
CONTINUOUS DC BUS CURRENT AVAILABLE FROM INTERNAL SUPPLY	30 A for three phase AC input
PEAK DC BUS CURRENT AVAILABLE FROM INTERNAL SUPPLY (MAXIMUM 2 SECONDS)	60 A for three phase AC input
INTERNAL SHUNT RESISTOR	20 $\Omega$ @ 100 W
SHUNT SWITCH-ON VOLTAGE *	390 V
BUS CAPACITANCE	1650 $\mu$ F
SHUNT FUSE (d=.25 inches, L=1.25 inches)	3 Amp motor delay @ 250 VAC
AC LINE FUSES (d=13/32 inches, L=1.50 inches)	20 Amp fast acting @ 250 VAC

<b>MECHANICAL SPECIFICATIONS</b>	
AC CONNECTOR: C1	Screw terminals
DC OUT AND EXTERNAL SHUNT CONNECTOR: C2	Screw terminals
SIGNAL CONNECTOR: P1 (optional) **	Optional Molex Connector
MOTOR CONNECTOR: P2	Screw terminals
SIGNAL CONNECTOR: P3	15 pin low density, female D-Sub
SIZE	9.24 x 6.37 x 6.11 inches 234.7 x 161.8 x 155.2 mm
WEIGHT	11 Lb. 5 Kg

\* If the shunt regulator is disabled the shut down voltage is 420 VDC.

\*\* Optional Molex connector replaces standard D-sub connector.

These amplifiers contain a rectifier bridge and filter capacitors to generate the DC bus internally from the AC input power. The DC bus voltage is 1.4 times AC voltage (RMS), e.g. 310 VDC from 220 VAC. During braking much of the stored mechanical energy is fed back into the power supply and charges the bus capacitor to a higher voltage. If this voltage reaches the amplifier's over-voltage shutdown point, output current and braking will cease. To ensure smooth braking of large inertial loads, a built-in "shunt regulator" is provided in the S60A40AC. The shunt regulator will switch on the internal power resistor when the bus voltage reaches 390 VDC. This allows the bus capacitor to discharge and thus lower the bus voltage. During regeneration, the regeneration LED will blink (solid green is non-regeneration mode). An external shunt resistor can be added in parallel to the internal resistor (between C2-3 and C2-4). Removing the jumper between C2-4 and C2-5 will disable the internal shunt resistor. If the shunt regulator becomes inoperative the over voltage protection on the amplifier will disable the drive if the regeneration energy causes the bus voltage to exceed 425 VDC.

**ORDERING INFORMATION:**

Model: S60A40ACX

X indicates current revision letter.

**TYPICAL SYSTEM WIRING:** See section "G".

**MOUNTING DIMENSIONS:** See page F-18.

# S60A SERIES THREE PHASE SINUSOIDAL BRUSHLESS SERVO AMPLIFIERS

## Model: S60A40

**FEATURES:**

- Surface-mount technology
- Small size, low cost, ease of use
- Optical isolation, see block diagram
- Sinusoidal drive and current control
- Four quadrant regenerative operation
- Agency Approvals:

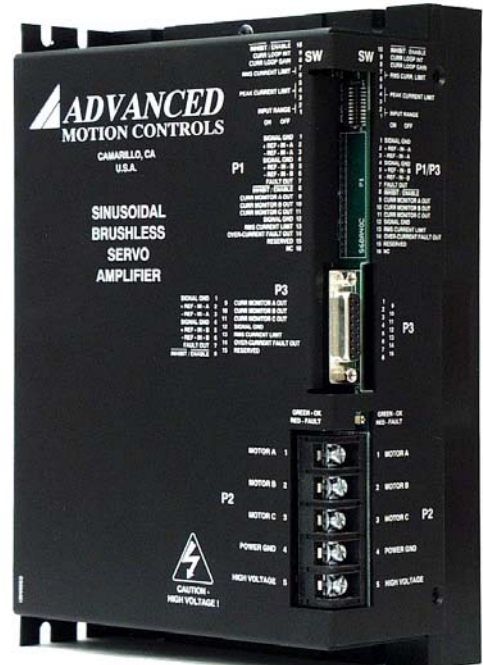

**BLOCK DIAGRAM:**

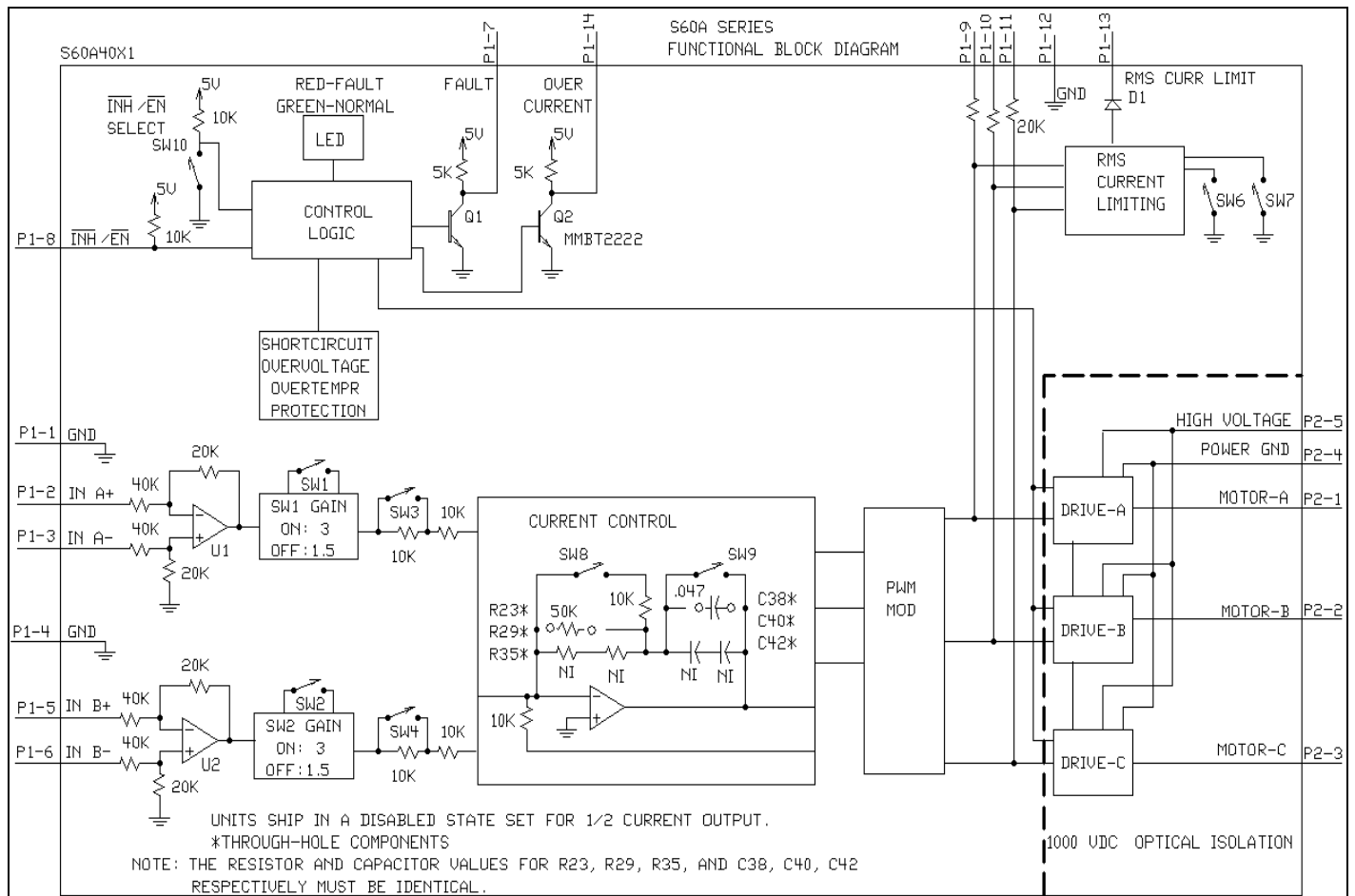

**ADVANCED MOTION CONTROLS**  
 3805 Calle Tecate, Camarillo, CA 93012 Tel: (805) 389-1935, Fax: (805) 389-1165

**DESCRIPTION:** The S60A40 Series PWM servo amplifiers are designed to drive three phase brushless motors with sine wave current at a high switching frequency. They require two sinusoidal command signals with a 120-degree phase shift (external commutation). The phase angle must correspond to the position of the motor rotor, while the signal amplitude controls the motor torque. All models typically interface directly with digital controllers. The amplifiers are fully protected against over-voltage, under-voltage, over-current, over-heating, and short-circuits. The S60A40 series amplifiers require only a single unregulated DC power supply (all logic and control voltages are generated internally). A red/green LED and two digital outputs indicate operating status. All signal inputs and outputs are optically isolated from the power section to eliminate the need for a transformer coupled power supply.

**SPECIFICATIONS:**

	<b>MODEL</b>
<b>POWER STAGE SPECIFICATIONS</b>	<b>S60A40</b>
DC SUPPLY VOLTAGE	60 – 400 V
PEAK CURRENT (2 sec. max., internally limited)	±60 A (42.4 Arms)
MAXIMUM CONTINUOUS CURRENT (internally limited)	±30 A (21.2 Arms)
MINIMUM LOAD INDUCTANCE *	600 µH
SWITCHING FREQUENCY	15 kHz ± 15 %
HEATSINK (BASE) TEMPERATURE RANGE	0° to +65° C, disables if >65° C
POWER DISSIPATION AT CONTINUOUS CURRENT	600 W
OVER-VOLTAGE SHUT-DOWN (self-reset)	420 V
BANDWIDTH (load dependent)	2.5 kHz

<b>MECHANICAL SPECIFICATIONS</b>	
POWER CONNECTOR: P2	Screw Terminals
SIGNAL CONNECTOR: P1 (optional) **	Optional Molex Connector
SIGNAL CONNECTOR: P3	15 pin low density, female D-Sub
SIZE	9.24 x 6.31 x 3.50 inches 234.7 x 160.2 x 88.9 mm
WEIGHT	5.64 lbs. 2.56 kg.

\* Low inductance motors require external inductors.

\*\* Optional Molex connector replaces standard D-sub connector.

## PIN FUNCTIONS:

CONNECTOR	PIN	NAME	DESCRIPTION / NOTES	I/O
P1/P3	1	SIGNAL GND	Signal ground	SGND
	2	+REF-IN-A	Differential reference input, maximum $\pm 15$ V, 40K input resistance	I
	3	-REF-IN-A		
	4	SIGNAL GND	Signal ground	SGND
	5	+REF-IN-B	Differential reference input, maximum $\pm 15$ V, 40K input resistance	I
	6	-REF-IN-B		
	7	FAULT OUT	This transistor output becomes high during short circuit, over-voltage, under voltage, and power-on reset. A red LED also indicates a fault condition.	O
	8	INHIBIT / ENABLE	This TTL level input signal turns off all power devices of the "H" bridge when pulled to ground with SW10=ON. If SW10 = OFF pulling this pin to ground will enable the amplifier. This inhibit will cause a fault condition and a red LED.	I
	9	CURRENT MONITOR A	Phase current monitor; 7.25 V = maximum peak current setting.	O
	10	CURRENT MONITOR B		
	11	CURRENT MONITOR C		
	12	SIGNAL GROUND	Signal ground	SGND
	13	RMS CURRENT LIMIT	The RMS current limit can be controlled by an external voltage; 5 V = maximum RMS current limit. This is referenced to P1-1. No input to this pin is necessary to obtain maximum current.	I
	14	OVER-CURRENT	This transistor output becomes high if RMS current (in any phase) exceeds RMS current limit.	O
	15	NC	Reserved	
	16	NC	Reserved (Not available on P3)	
P2	1	MOTOR A	Motor phase A connection	O
	2	MOTOR B	Motor phase B connection	O
	3	MOTOR C	Motor phase C connection	O
	4	POWER GND	Power ground	PGND
	5	HIGH VOLTAGE	DC power input	I

**SWITCH FUNCTIONS:**

SWITCH	FUNCTION DESCRIPTION	SETTING	
		ON	OFF
1	Input Range Selection*	Input range $\pm 5$ V $\pm 5$ V = Max. current when SW1, 2 = ON	Input range $\pm 10$ V $\pm 10$ V = Max. current when SW1, 2 = OFF
2			
3	Peak Current Limit**	The peak current limit equals 100% of the maximum peak current when SW3 and SW4 are ON.	The peak current limit equals 50% of the maximum peak current when SW3 and SW4 are OFF.
4			
5	Reserved		
6	RMS Current Limit	See Table 1 below.	
7			
8	Current Loop Gain***	Decrease	Increase
9	Current Loop Integrator***	Recommended setting is OFF.	
10	INHIBIT/ENABLE SELECT	P1-8: INHIBIT With SW10=ON, pull P1-8 to ground to inhibit the amplifier.	P1-8: ENABLE With SW10=OFF, pull P1-8 to ground to enable the amplifier.

\* Switches 1 and 2 must be set the same.

\*\* Switches 3 and 4 must be set the same.

\*\*\* See item "6.3 Current Loop Adjustments" in section G for more information.

Units are shipped set for  $\frac{1}{2}$  current output via SW3 and SW4=off and in the disabled state via SW10=off.

**TABLE 1:**

SW6	SW7	PERCENTAGE OF MAXIMUM CONTINUOUS CURRENT
ON	ON	100%
OFF	ON	100%
ON	OFF	50%
OFF	OFF	25%

**CURRENT LIMIT:**

Current limiting for each motor winding is independent. The peak current is maintained for two seconds. If the RMS value of the winding current exceeds the RMS current limit the amplifier shuts off. The shut off condition is indicated by a high OVER CURRENT signal, a high FAULT signal, and a blinking red LED. The amplifier will re-enable when the RMS current returns to values within the RMS current limit range.

**INPUT SIGNAL ISOLATION:** All pins on P1/P3 are optically isolated (1000 V) from P2.

**ORDERING INFORMATION:**

Model: S60A40X

X indicates the current revision letter.

**TYPICAL SYSTEM WIRING:** See section "G".

**MOUNTING DIMENSIONS:** See page F-17.



